



Barracuda

Web Application Firewall™

Barracuda Networks

Quick Start Guide

Kurzanleitung

Guía de Inicio Rápido

Guide de Démarrage Rapide

Guida Rapida

Hızlı Başlangıç Rehberi

クイックスタートガイド

Dear Valued Customer,

Thank you for choosing a Barracuda Web Application Firewall appliance. Please contact technical support if you have any questions or need help. Barracuda Networks is on a mission to protect and support our customers for life, so we're here for you 24x7.

Our team is driven by five core values: think customer, drive innovation, take ownership, deliver outcomes, and succeed together.

More than 200,000 customers around the world trust Barracuda Networks to safeguard their employees, data, and applications from a wide range of threats with easy, comprehensive, and affordable solutions for email protection, application and cloud security, network security, and data protection.

Let us know what we can do to help secure your journey.

Sincerely,



Rohit Ghai
President & CEO

Technical Support

Barracuda Networks' award-winning technical support is available 24x7 worldwide. You'll always be connected with a person and not an automated system. If you have technical problems or questions about your Barracuda Networks product, please do not hesitate to reach out.

- Open a Technical Support case online: barracuda.com/support
- Call Technical Support: barracuda.com/support/phone
- To cover your evolving business needs, Barracuda Networks offers a variety of support options. Visit barracuda.com/support/premium

Barracuda Networks Community

Access helpful tools and information to get the most out of your Barracuda Networks solution: barracuda.com/join-community

Documentation

Get technical documentation online: campus.barracuda.com

Table of Contents

English

Setup	1-6
Support	6
Security	7
Warranty	8

Deutsch

Sicherheit	9
Garantie	10

Español

Seguridad	11
Garantía	12

Français

Sécurité	13
Garantie	14

Italiano

Sicurezza	15
Garanzia	16

Türk

Güvenlik	17
Garanti	18

日本語

セキュリティ	19
保証	20

1

Getting Started

This guide describes how to set up your Barracuda Web Application Firewall in Reverse Proxy (Two-Arm Proxy or One-Arm Proxy) mode. For additional deployment options, see <https://campus.barracuda.com/doc/27460361/>

Barracuda Networks recommends reading these instructions fully before starting to install.

To install and configure, you need the following:

- Barracuda Web Application Firewall, AC Power Cord (included)
- Ethernet Cables
- Mounting Rails (model 660 and higher)
- VGA Monitor (recommended)
- USB Keyboard (recommended)

2

Install

To install the Barracuda Web Application Firewall:

1. **Secure** the appliance in your environment.
2. **Connect** an Ethernet cable from your network switch to the Ethernet port on the back of the Barracuda Web Application Firewall.
3. **Connect** the back-end Server network switch to the **LAN** port. In One-Arm-Proxy mode, the back-end Servers are reachable from the Barracuda Web Application Firewall WAN interface.
4. **Connect** your monitor and keyboard cable.
5. **Connect** your power source; the AC input voltage range is 100-240 volts at 50/60 Hz. Turn on the appliance.

Multiport Appliances (Models 86x and 96x)

 **Note:** Multiport appliances include 4 WAN ports (top) and 4 LAN ports (bottom) on the front panel. Models 96x include an additional WAN and LAN port on the front panel.

Barracuda Web Application Firewall (Multiport Appliance)

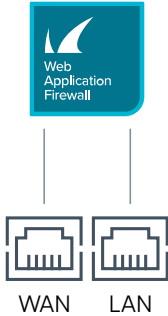

Two-Arm Proxy Mode

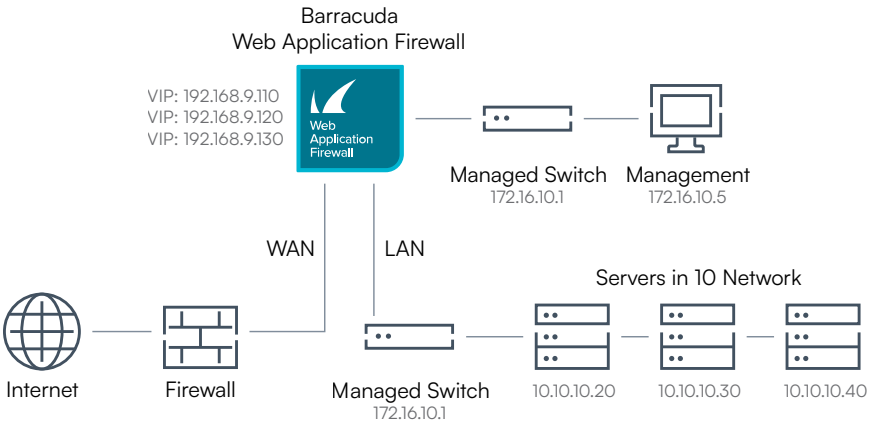

3

Configure IP Address and Network

With a monitor connected, after it is fully booted, the login prompt displays. The default WAN IP address is 192.168.200.200.

1. Enter **admin** as the **Username**.
2. Enter **<numeric portion of the serial# of the appliance>** as the **Password**.
3. Go to **TCP/IP Configuration**, and configure the **WAN IP Address**, **Netmask**, **Default Gateway**, **Primary DNS Server**, and **Secondary DNS Server** as appropriate for your network.
4. Save your changes.

4

Open Firewall Ports



Note: For maximum security, place your Barracuda Web Application Firewall behind a corporate firewall.

If your Barracuda Web Application Firewall is located behind a corporate firewall, open the following ports on your firewall to ensure proper operation:

PORT	DIRECTION	TCP	UDP	USAGE
22/8788	Out	Yes	No	Technical Support Services
25	In/Out	Yes	No	Email Alerts
53	Out	Yes	Yes	Domain Name Service (DNS)
80/8000	Out	Yes	No	Firmware and Definition Updates
123	Out	No	Yes	Network Time Protocol (NTP)

5

Complete Configuration

In a browser, enter `http://` followed by the Barracuda Web Application Firewall default WAN IP address configured in *Step 3 Configure IP Address and Network*, and the default HTTP port, for example, `http://192.168.200.200:8000`.



Note: To ensure the highest security, use HTTPS to configure your Barracuda Web Application Firewall web interface. In addition, Barracuda Networks recommends requiring HTTPS to connect to the Barracuda Web Application Firewall. To configure this setting, go to the **ADVANCED > Secure Administration** page.

1. In the login screen, enter **admin** for the **Username** and **<numeric portion of the serial# of the appliance>** for the **Password**, and click **Sign in**.
2. Go to **BASIC > IP Configuration**, and perform the following:
 - Verify the **IP Address** and **Subnet Mask**
 - Verify the **Primary** and **Secondary DNS Server**
3. Click **Save**.

6 Activate Subscription

1. Go to **BASIC > Dashboard**, and under **Subscription Status**, verify the **Energize Updates** subscription status is **Current**.
2. If the status is **Not Activated**, click the activation link and complete your subscription activation. If you are connected to the Internet, the activation status automatically updates once you reload the **BASIC > Dashboard** page.
3. If your network firewall prevents the Barracuda Web Application Firewall from automatically updating the activation status, manually enter the activation code on the **BASIC > Dashboard** page.

7 Update the Firmware

Go to **ADVANCED > Firmware Update**. If there is a new **Latest General Release** available:

1. Click **Download Now**; allow the download to complete. Do not power off during update or download.
2. Click **Apply Now**; the appliance automatically reboots once the process is complete.

8

Change the Administrator Password

Go to **BASIC > Administration** and change the administrator password.

9

Configure a Service

Create a Service by following the instructions in Barracuda Networks Campus: <https://campus.barracuda.com/doc/4259865/>

Once the service is configured, the Barracuda Web Application Firewall is ready for operation. Incoming traffic for your website is intercepted and inspected and then forwarded to the Server. By default, the configured Service is in Passive Mode, so all traffic is allowed to pass through, but any anomalies or intrusions are logged on the **BASIC > Web Firewall Logs** page.

10

Other Deployment Modes

One-Arm Proxy Mode

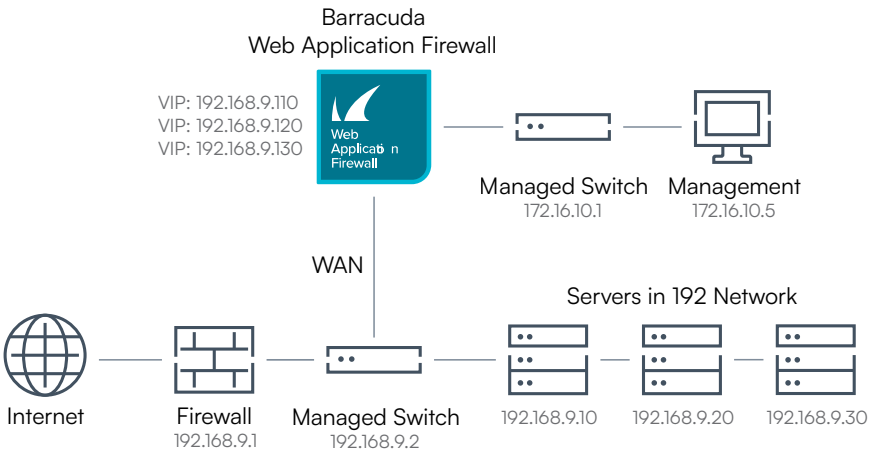

Bridge Mode

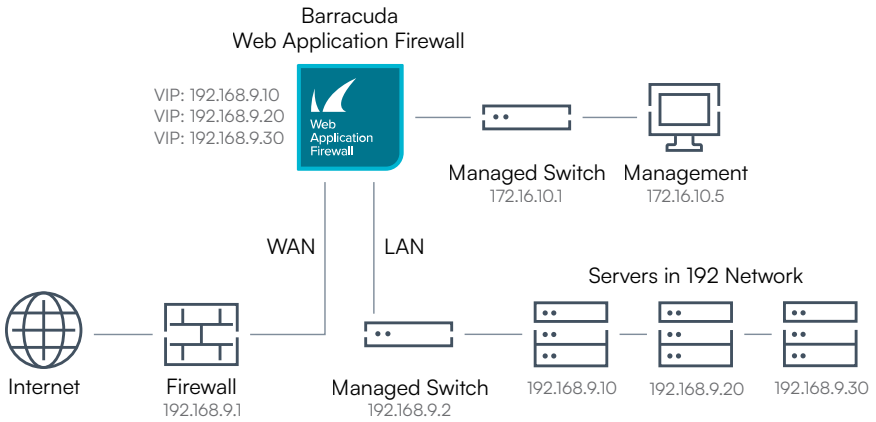

Technical Support

Barracuda Networks' award-winning technical support is available 24x7 worldwide. You'll always be connected with a person and not an automated system. If you have technical problems or questions about your Barracuda Networks product, please do not hesitate to reach out.

- Open a Technical Support case online: barracuda.com/support
- Call Technical Support: barracuda.com/support/phone
- To cover your evolving business needs, Barracuda Networks offers a variety of support options. Visit barracuda.com/support/premium

Barracuda Networks Community

Access helpful tools and information to get the most out of your Barracuda Networks solution: barracuda.com/join-community

Documentation

Get technical documentation online: campus.barracuda.com

Electrical Safety

Follow these basic electrical safety precautions to protect yourself from harm and to protect the appliance from damage:

- Be aware of the power switch locations on the appliance chassis, the emergency power-off switch for the housing room, the disconnection switch, and the electrical outlet. This awareness allows quick removal of electrical power from the system should an electrical accident occur.
- Do not work alone when working with high voltage components.
- When working around exposed electrical circuits, another person familiar with the power-off controls should be nearby to switch off the power if necessary.
- Use only one hand when working with powered-on electrical equipment. This prevents making a complete circuit, which can cause electrical shock. Use extreme caution when using metal tools, which can easily damage electrical components or circuit boards when they come into contact with them.
- Do not use mats designed to decrease electrostatic discharge to protect from electrical shock. Instead, use rubber mats that have been specifically designed as electrical insulators.
- The power supply power cord must include a grounding plug and must be plugged into grounded electrical outlets.
- To prevent fire or shock hazard, do not expose the unit to rain or moisture, or install this product near water.
- Avoid installing this product during a lightning storm.
- Ensure that the air vents (openings along the sides and back) are never blocked and that there is sufficient airflow through the vents to prevent over-heating.

General Safety

- Keep the area around the appliance clean and free of clutter.
- Locate a safe and dry location to set this product, keeping it away from wet surfaces/surroundings.
- While working on the system, do not wear loose clothing, such as neckties and unbuttoned shirt sleeves, which can contact electrical circuits or be pulled into a cooling fan.
- Remove any jewelry or metal objects from your body, which can act as excellent metal conductors, creating short circuits, and potentially harming you if they contact printed circuit boards or powered areas.
- For plugged in equipment, the socket-outlet must be installed near the equipment and be easily accessible.

Electrostatic Discharge Precautions

Electrostatic discharge (ESD) is generated by two objects with different electrical charges coming into contact with one another. An electrical discharge, which can damage electronic components and printed circuit boards, neutralizes this difference.

- Use a grounded wrist strap designed to prevent static discharge.
- Keep all components and printed circuit boards (PCBs) in their antistatic bags until ready for use.
- Touch a grounded metal object before removing the board from the antistatic bag.
- Do not let components or PCBs contact your clothing, which may result in a charge despite wearing a wrist strap.
- Handle a board by its edges only; do not touch its components, peripheral memory modules, or contacts.
- When handling chips or modules, avoid touching their pins.
- Put the server board and peripherals back into their antistatic bags when not in use.
- For grounding purposes, make sure your computer chassis provides excellent conductivity between the power supply, the case, the mounting fasteners, and the server board.
- After accessing the inside of a system, close the system back up and secure it to the rack unit with the retention screws after ensuring that all connections have been made.

United States Patents

This Barracuda Networks product is covered by one or more of the following U.S. patents:

7010611	7861300	8069244	8555365	8849836	9871817	10574676	11126417	11563757
7093287	7877789	8122493	8559450	8977661	9881271	10623441	11134058	
11588724								
7093294	7898953	8204948	8571042	9021017	9918346	10761825	11145221	11645943
7103913	7917756	8219644	8725704	9152466	9942050	10778714	11159565	11665195
7149222	7917943	8280895	8726384	9195668	10044677	10778717	11250130	
11750647								
7149795	7930428	8285997	8775604	9224117	10050795	10834129	11356469	
7254038	7970899	8434140	8788597	9262643	10083307	10860715	11457040	
7272155	7974288	8443193	8788831	9373001	10171582	10958662	11463409	
7328247	7987267	8447856	8789178	9465598	10333709	11025655	11463460	
7688815	7996475	8463797	8831030	9680818	10404726	11050714	11537412	
7788291	8042169	8484741	8838965	9699207	10439990	11068569	11546375	
7836267	8050251	8527549	8843612	9755988	10542572	11074088	11558419	

Software License

Barracuda Networks software is provided under license from Barracuda Networks, Inc. and other licensors, and certain of the programs included in the software may be provided under the GNU General Public License (GPL) or the Lesser General Public License (LGPL). In accordance with the terms of the GPL and LGPL, you may request a copy of the relevant source code. This offer is valid for up to three years from the date of original purchase of the product. For details and information about the applicable licenses, please contact Barracuda Networks at contact@barracuda.com.

Barracuda Networks software license terms are located at:
<https://www.barracuda.com/legal/software-license-agreement>

Warranty

The hardware and software is warranted as set forth in the warranty located at:
<https://www.barracuda.com/legal/warranty>

Export Compliance

Barracuda Networks is committed to complying fully with U.S. government and host country government laws and regulations, including export and import laws. Any person or entity exporting or re-exporting Barracuda Networks products directly or indirectly and via any means, including electronic transfer, is wholly responsible for doing so in accordance with the U.S. Export Administration Regulations and the laws of host countries and must obtain and maintain all approvals and licenses from the appropriate governmental authorities. U.S. export laws restrict product from being shipped to embargoed countries and denied persons or entities. For details on U.S. export laws, please visit <http://www.bis.doc.gov>.

To assist you meet your obligations with regard to export compliance, Barracuda Networks provides a product export classification matrix located at: www.barracuda.com/tradecompliance.

Should your organization have any questions regarding this obligation or our trade compliance policies, please contact your Barracuda Networks Channel Account Manager or send an email to TradeCompliance_Team@barracuda.com.



Sicherheit im Umgang mit Elektrizität

Befolgen Sie diese grundlegenden Regeln zur elektrischen Sicherheit, um sich selbst und das Gerät vor Schaden zu bewahren:

- Merken Sie sich die Orte, an denen sich der Ein-/Aus-Schalter am Gerätegehäuse, der Notfall-Ausschalter des Serverraums, der Trennschalter und die Steckdose befinden. Diese Kenntnisse ermöglichen Ihnen das rasche Abschalten des Stroms bei einem Elektrizitätsunfall.
- Arbeiten Sie mit Hochspannungskomponenten nur in Anwesenheit einer zweiten Person.
- Beim Arbeiten in der Nähe freiliegender stromführender Teile sollte sich eine weitere Person, die weiß wie der Stromkreis unterbrochen werden kann, in der Nähe befinden, um die Stromversorgung zu unterbrechen, falls dies nötig wird.
- Verwenden Sie nur eine einzige Hand, wenn Sie mit eingeschalteten elektrischen Komponenten arbeiten. Dadurch verhindern Sie die Bildung eines geschlossenen Kreises, der zum Elektroschock führen kann. Seien Sie extrem vorsichtig mit Werkzeugen aus Metall, die elektrische Komponenten und Schaltkreise leicht beschädigen können, wenn sie mit ihnen in Kontakt kommen.
- Verwenden Sie keinen Antistatik-Matten als Schutzmaßnahme gegen Elektroschocks. Verwenden Sie stattdessen Gummimatten, die speziell zum Zweck der elektrischen Isolierung hergestellt wurden.
- Das Stromkabel muss über einen Erdungsstecker verfügen und darf nur an geerdete Steckdosen angeschlossen werden.
- Um Feuer oder Elektroschocks zu vermeiden, setzen Sie das Gerät keinem Regen und keiner Feuchtigkeit aus und stellen Sie es nicht in der Nähe von Wasser auf.
- Installieren Sie dieses Produkt nicht während eines Gewitters.
- Stellen Sie sicher, dass die Lüftungsöffnungen (Öffnungen an den Seiten und an der Rückseite) niemals verschlossen werden und genügend Frischluftzufuhr an den Lüftungsöffnungen vorhanden ist, um Überhitzung zu vermeiden.

Generelle Sicherheit

- Sorgen Sie dafür, dass die Umgebung des Gerätes sauber und aufgeräumt ist.
- Suchen Sie nach einem sicheren und trockenen Ort, um das Produkt aufzustellen. Halten Sie es von nassen Oberflächen und Umgebungen fern.
- Tragen Sie während der Arbeit am System keine zu weite Kleidung wie Krawatten oder unbefestigte Hemdsärmel, die mit dem Stromkreis in Berührung kommen oder in Kühlerventilatoren hineingezogen werden könnten.
- Entfernen Sie jeglichen Schmuck und Metallobjekte von Ihrem Körper, die Elektrizität gut leiten können. Es besteht das Risiko, dass diese Gegenstände Kurzschlüsse erzeugen und Sie gefährden, wenn sie mit Platinen mit gedruckten Schaltkreisen oder stromführenden Bereichen in Berührung kommen.
- Für ans Stromnetz anzuschließende Geräte muss die Steckdose nahe des Gerätes installiert und leicht zugänglich sein.

Vorsichtsmaßnahmen gegen elektrostatische Entladung

Elektrostatische Entladung (ESD) wird von zwei Gegenständen ausgelöst, die unterschiedlich elektrisch geladen sind und miteinander in Kontakt kommen. Eine elektrische Entladung, die elektronische Komponenten und Platinen mit gedruckten Schaltkreise beschädigen kann, neutralisiert diesen Ladungsunterschied.

- Verwenden Sie ein geerdetes Armband, um statische Entladungen zu vermeiden.
- Belassen Sie alle Komponenten und Platinen mit gedruckten Schaltkreisen (PCBs) in ihren antistatischen Verpackungen, bis Sie bereit sind, sie einzusetzen.
- Berühren Sie ein geerdetes Metallobjekt, bevor Sie die Platine aus der antistatischen Verpackung nehmen.
- Lassen Sie Komponenten oder PCBs nicht mit Ihrer Kleidung in Berührung kommen, denn dies könnte trotz Tragens eines geerdeten Armbandes zu einer Entladung führen.
- Berühren Sie eine Platine nur an ihren Außenkanten. Vermeiden Sie die Berührung ihrer Komponenten, peripheren Speichermodule oder Kontakte.
- Wenn Sie mit Chips oder Modulen arbeiten, vermeiden Sie das Berühren der Kontaktstifte.
- Geben Sie die Serverplatine und die Peripheriekomponenten zurück in ihre antistatischen Verpackungen, wenn sie nicht in Verwendung sind.
- Um gute Erdung zu gewährleisten, muss Ihr Computergehäuse hervorragende elektrische Leitfähigkeit zwischen Stromversorgung, Gehäuse, Montagebefestigungen und Serverplatine aufweisen.
- Nach der Arbeit mit Komponenten im Inneren eines Computersystems verschließen Sie das Gehäuse wieder und sichern Sie es mittels der Schrauben im Rack, nachdem Sie sich davon überzeugt haben, dass alle Verbindungen hergestellt sind.

Patente in den Vereinigten Staaten

Dieses Barracuda Networks-Produkt ist Teil eines oder mehrerer der folgenden U.S.-Patente:

7010611	7861300	8069244	8555365	8849836	9871817	10574676	11126417	11563757
7093287	7877789	8122493	8559450	8977661	9881271	10623441	11134058	
11588724								
7093294	7898953	8204948	8571042	9021017	9918346	10761825	11145221	11645943
7103913	7917756	8219644	8725704	9152466	9942050	10778714	11159565	11665195
7149222	7917943	8280895	8726384	9195668	10044677	10778717	11250130	
11750647								
7149795	7930428	8285997	8775604	9224117	10050795	10834129	11356469	
7254038	7970899	8434140	8788597	9262643	10083307	10860715	11457040	
7272155	7974288	8443193	8788831	9373001	10171582	10958662	11463409	
7328247	7987267	8447856	8789178	9465598	10333709	11025655	11463460	
7688815	7996475	8463797	8831030	9680818	10404726	11050714	11537412	
7788291	8042169	8484741	8838965	9699207	10439990	11068569	11546375	
7836267	8050251	8527549	8843612	9755988	10542572	11074088	11558419	

Softwarelizenz

Barracuda Networks-Software wird unter Lizenz von Barracuda Networks, Inc., und anderen Lizenzgebern bereitgestellt. Bestimmte Programme, die in der Software enthalten sind, könnten der GNU General Public License (GPL) oder der Lesser General Public License (LGPL) unterstehen. In Übereinstimmung mit den Bestimmungen der GPL und der LGPL können Sie eine Kopie des relevanten Quellcodes anfordern. Dieses Angebot gilt während eines Zeitraums von bis zu drei Jahren ab dem Datum des Originalkaufs des Produktes. Für Details und Informationen über die anzuwendenden Lizenzen kontaktieren Sie bitte Barracuda Networks unter contact@barracuda.com.

Barracuda Networks-Softwarelizenzbedingungen befinden sich auf:

<https://www.barracuda.com/legal/software-license-agreement>.

Garantie

Auf die Hardware und Software wird Garantie gewährt wie unter

<https://www.barracuda.com/legal/warranty-beschrieben>.

Exportkonformität

Barracuda Networks bekennt sich zur vollen Übereinstimmung mit den Gesetzen und Bestimmungen der Regierung der Vereinigten Staaten von Amerika und des Importlandes, inklusive der gesetzlichen Export- und Importbestimmungen. Jede natürliche oder juristische Person, die Produkte von Barracuda Networks auf welche Art auch immer, inklusive elektronischer Methoden, exportiert oder re-exportiert, ist vollumfänglich verantwortlich dafür, dass dies in Übereinstimmung mit den U.S. Export Administration Regulations und den gesetzlichen Bestimmungen der Importländer geschieht, und muss jegliche Genehmigungen und Lizenzen von den entsprechenden Regierungsstellen einholen und pflegen. Die Exportgesetze der Vereinigten Staaten von Amerika verbieten den Export von Produkten in mit einem Embargo belegte Länder sowie mit einem entsprechenden Verbot belegte natürliche oder juristische Personen. Besuchen Sie bitte <http://www.bis.doc.gov> um Details der Exportgesetze der Vereinigten Staaten von Amerika einzusehen.

Zu Ihrer Unterstützung in der Wahrnehmung Ihrer Pflichten hinsichtlich Exportkonformität stellt Barracuda Networks eine Produktexport-Klassifizierungsmatrix zur Verfügung, die Sie hier finden:

www.barracuda.com/tradecompliance.

Falls Ihre Organisation Fragen hinsichtlich dieser Verpflichtungen oder unserer

Handelskonformitätsrichtlinien an uns richten möchte, kontaktieren Sie bitte Ihren Barracuda Networks Channel Account Manager oder senden Sie ein E-Mail an TradeCompliance_Team@barracuda.com.



Seguridad Eléctrica

Sigue estas medidas básicas sobre seguridad eléctrica para protegerte y proteger el dispositivo de cualquier daño:

- Presta atención a la ubicación de los interruptores de alimentación en el bastidor del dispositivo, al interruptor de parada de emergencia del compartimiento de la carcasa, al interruptor de desconexión y a la toma de corriente. Este nivel de alerta te permite suprimir rápidamente la alimentación eléctrica del sistema en caso de que se produzca un accidente eléctrico.
- No trabajes solo cuando manipules componentes de alta tensión.
- Cuando trabajes cerca de circuitos eléctricos al descubierto, deberías estar con una persona familiarizada con los controles de desconexión para apagar la alimentación si fuera necesario.
- Utiliza solo una mano cuando trabajes con equipos eléctricos encendidos. De esta manera se evita completar el circuito, lo que podría provocar una descarga eléctrica. Presta mucha atención al utilizar herramientas metálicas ya que pueden dañar fácilmente los componentes eléctricos o las placas de circuitos si entran en contacto con ellos.
- No utilices alfombrillas diseñadas para disminuir la descarga electrostática para protegerte de las descargas eléctricas. En su lugar, utiliza alfombrillas de goma diseñadas especialmente como aislantes eléctricos.
- El cable de alimentación debe incluir una conexión a tierra y debe estar conectado a tomas con conexión a tierra.
- Para evitar riesgos de incendio o de descarga eléctrica, no expongas el equipo a la lluvia o a la humedad, ni lo instales cerca del agua.
- Evita la instalación de este producto durante una tormenta eléctrica.
- Asegúrate de que los respiraderos (aperturas en los laterales y en la parte trasera) nunca estén bloqueados y de que exista suficiente flujo de aire a través ellos para evitar el sobrecalentamiento.

Seguridad General

- Mantén la zona que rodea el dispositivo limpia y ordenada.
- Localiza una zona seca y segura para colocar este producto, alejado de entornos y superficies húmedos.
- Cuando trabajes en el sistema, no utilices ropa holgada, como corbatas o mangas de camisa desabrochadas, ya que podría entrar en contacto con los circuitos eléctricos o quedar atrapada en un ventilador.
- Retira todos los objetos metálicos y joyas de tu cuerpo, ya que puedan actuar como excelentes conductores metálicos, creando cortocircuitos y posibles daños personales si entran en contacto con las placas de circuito impreso o las zonas con energía.
- Para conectar el equipo, el enchufe debe estar instalado cerca del equipo y debe ser fácilmente accesible.

Precauciones ante Descargas Electroestáticas

La descarga electrostática (ESD por sus siglas en inglés) se genera a partir de dos objetos con diferentes cargas eléctricas que entran en contacto. Una descarga eléctrica, que puede dañar los componentes electrónicos y las placas de circuito impreso, neutraliza esta diferencia.

- Utiliza una pulsera con conexión a tierra para evitar la descarga estática.
- Guarda todos los componentes y placas de circuito impreso (PCB) en sus bolsas antiestáticas hasta que estén listas para su uso.
- Toca un objeto metálico conectado a tierra antes de retirar la placa de la bolsa antiestática.
- No permitas que los componentes o placas de circuito impreso entren en contacto con tu ropa, ya que podría provocar una carga a pesar de llevar una pulsera.
- Manipula la placa únicamente por sus bordes; no toques sus componentes, ni los módulos de memoria periféricos o contactos.
- Cuando manipules los chips o módulos, evita tocar sus terminales.
- Vuelve a colocar la placa del servidor y los periféricos en sus bolsas antiestáticas cuando no los utilices.
- Para la conexión a tierra, comprueba que el chasis del ordenador proporcione una conductividad excelente entre la fuente de alimentación, la carcasa, las abrazaderas de montaje y la placa del servidor.
- Después de acceder al interior de un sistema, vuelve a cerrarlo y fíjalo a la unidad del bastidor con los tornillos de retención una vez comprobadas todas las conexiones.

Patentes de los Estados Unidos

Este producto de Barracuda Networks está protegido por una o más de las siguientes patentes de los Estados Unidos:

7010611	7861300	8069244	8555365	8849836	9871817	10574676	11126417	11563757
7093287	7877789	8122493	8559450	8977661	9881271	10623441	11134058	
11588724								
7093294	7898953	8204948	8571042	9021017	9918346	10761825	11145221	11645943
7103913	7917756	8219644	8725704	9152466	9942050	10778714	11159565	11665195
7149222	7917943	8280895	8726384	9195668	10044677	10778717	11250130	
11750647								
7149795	7930428	8285997	8775604	9224117	10050795	10834129	11356469	
7254038	7970899	8434140	8788597	9262643	10083307	10860715	11457040	
7272155	7974288	8443193	8788831	9373001	10171582	10958662	11463409	
7328247	7987267	8447856	8789178	9465598	10333709	11025655	11463460	
7688815	7996475	8463797	8831030	9680818	10404726	11050714	11537412	
7788291	8042169	8484741	8838965	9699207	10439990	11068569	11546375	
7836267	8050251	8527549	8843612	9755988	10542572	11074088	11558419	

Licencia del Software

El software de Barracuda Networks se entrega bajo licencia de Barracuda Networks, Inc. y otros cedentes, y determinados programas incluidos en el software pueden entregarse bajo la Licencia Pública General de GNU (GPL por sus siglas en inglés) o bajo la Licencia Pública General Reducida de GNU (LGPL por sus siglas en inglés). De acuerdo con los términos de la GPL y de la LGPL, puedes solicitar una copia del código fuente pertinente. Esta oferta es válida hasta un máximo de tres años desde la fecha de la compra original del producto. Para obtener más detalles e información sobre las licencias aplicables, ponte en contacto con Barracuda Networks en contact@barracuda.com.

Las condiciones de la licencia de software de Barracuda Networks se encuentran en: <https://www.barracuda.com/legal/software-license-agreement>

Garantía

El hardware y el software están garantizados según se establece en la garantía que se encuentra en: <https://www.barracuda.com/legal/warranty>

Cumplimiento Normativo en Exportaciones

Barracuda Networks se compromete a cumplir plenamente con las leyes y normativas del gobierno de los Estados Unidos y del gobierno del país anfitrión, incluyendo la legislación sobre importación y exportación. Cualquier persona o entidad que exporte o reexporte productos de Barracuda Networks directa o indirectamente, y por cualquier medio, incluyendo transferencia electrónica, es totalmente responsable de hacerlo de acuerdo con la Normativa de la Administración Estadounidense en materia de Exportación y con la legislación de los países anfitriones y debe obtener y conservar todas las aprobaciones y licencias de las autoridades gubernamentales pertinentes. Las leyes de exportación estadounidenses limitan la comercialización de productos a países sujetos a embargos y a entidades o personas prohibidas. Para más información sobre las leyes de exportación estadounidenses, visita <http://www.bis.doc.gov>.

Para ayudarte a satisfacer tus obligaciones relacionadas con el cumplimiento de las exportaciones, Barracuda Networks ofrece una matriz de clasificación para la exportación de productos en: www.barracuda.com/tradecompliance.

Si tu organización tuviera alguna duda relacionada con esta obligación o con el cumplimiento de nuestras políticas comerciales, ponte en contacto con tu gestor de cuentas de canal de Barracuda Networks o envíanos un correo electrónico a TradeCompliance_Team@barracuda.com.



Sécurité Électrique

Tenez compte des consignes de sécurité élémentaires suivantes pour vous protéger de dangers et éviter un endommagement du système:

- Faites attention à l'emplacement des interrupteurs de marche-arrêt sur le châssis du système, le bouton d'arrêt d'urgence de la salle d'hébergement, l'interrupteur de déconnexion et la prise électrique. Le fait de savoir où ils se trouvent permet une mise hors tension rapide du système en cas d'incident électrique.
- Ne pas travailler seul sur des composants haute tension.
- Lors de travaux à proximité de circuits électriques exposés, une autre personne connaissant les dispositifs de mise hors tension doit se trouver à proximité pour mettre hors tension si nécessaire.
- Utilisez une seule main lors de travaux sur des équipements électriques sous tension. Ceci permet d'éviter de fermer le circuit et ainsi de provoquer un choc électrique. Soyez extrêmement prudent lors de l'utilisation d'un outillage métallique, ceci risquant aisément d'endommager des composants électriques ou circuits imprimés, lors d'une entrée en contact.
- Ne pas utiliser de nattes destinées à réduire les décharges électrostatiques pour protéger contre les chocs électriques. Au lieu de cela, utilisez des nattes en caoutchouc spécialement conçues en tant qu'isolants électriques.
- Le cordon secteur d'alimentation doit prévoir une prise de terre et doit être branché à une prise électrique mise à la terre.
- Pour éviter les incendies ou les risques de choc électrique, n'exposez l'appareil ni à la pluie, ni à l'humidité et ne pas l'installer à proximité d'eau.
- Évitez d'installer ce produit pendant un orage.
- Assurez-vous que la ventilation (les ouvertures latérales et à l'arrière) soit toujours dégagée et qu'un flux d'air suffisant traverse ces ouvertures pour éviter une surchauffe.

Sécurité Générale

- Gardez les alentours de l'appareil propres et ordonnés.
- Localisez un endroit sûr et sec pour installer ce produit, tout en le gardant à l'écart de surfaces/d'un environnement humides.
- Lors de travaux réalisés sur le système, ne pas porter de vêtements amples, tels qu'une cravate et des manches de chemises déboutonnées risquant d'entrer en contact avec des circuits électriques ou d'être happés par un ventilateur.
- Enlevez tout bijou ou objet métallique que vous portez, celui-ci risquant d'agir comme un excellent conducteur métallique et donc de créer des courts-circuits et éventuellement de vous blesser, s'il entre en contact avec des circuits imprimés ou des zones sous tension.
- Dans le cadre d'un équipement branché, le socle de la prise de courant doit se trouver près de l'équipement et être aisément accessible.

Mesures de Protection ESD

Une décharge électrostatique (ESD) est causée par deux objets ayant des charges électriques différentes et entrant en contact l'un avec l'autre. Une décharge électrique risquant d'endommager des composants électroniques et des circuits imprimés neutralise cette différence.

- Utilisez un bracelet de mise à la terre pour éviter les décharges électrostatiques.
- Conservez tous les composants et les circuits imprimés (PCB) dans leur sachet anti-statique jusqu'à leur utilisation.
- Touchez un objet métallique mis à la terre avant de sortir le circuit imprimé du sachet anti-statique.
- Ne laissez pas des composants ou PCB entrer en contact avec vos vêtements, ceci risquant d'entraîner une décharge électrostatique malgré le port d'un bracelet anti-statique.
- Manipulez une carte de circuit imprimé en la tenant uniquement par les coins. Ne pas toucher ses composants, modules mémoire périphériques ou contacts.
- Lors de la manutention de puces ou modules, évitez de toucher leurs contacts.
- Remettez la carte serveur et les périphériques dans leurs sachets anti-statiques, lorsque vous ne les utilisez pas.
- À des fins de mise à la terre, assurez-vous que le châssis de votre ordinateur fournisse une excellente conductivité entre l'alimentation électrique, le boîtier, les fixations de montage et la carte serveur.
- Après avoir accédé à l'intérieur du système, refermez l'arrière de ce dernier et arrimez-le au rack à l'aide des vis de serrage, après vous être assuré d'avoir tout raccordé.

Brevets Américains

Ce produit Barracuda Networks est couvert par un ou plusieurs brevets Américains:

7010611	7861300	8069244	8555365	8849836	9871817	10574676	11126417	11563757
7093287	7877789	8122493	8559450	8977661	9881271	10623441	11134058	
11588724								
7093294	7898953	8204948	8571042	9021017	9918346	10761825	11145221	11645943
7103913	7917756	8219644	8725704	9152466	9942050	10778714	11159565	11665195
7149222	7917943	8280895	8726384	9195668	10044677	10778717	11250130	
11750647								
7149795	7930428	8285997	8775604	9224117	10050795	10834129	11356469	
7254038	7970899	8434140	8788597	9262643	10083307	10860715	11457040	
7272155	7974288	8443193	8788831	9373001	10171582	10958662	11463409	
7328247	7987267	8447856	8789178	9465598	10333709	11025655	11463460	
7688815	7996475	8463797	8831030	9680818	10404726	11050714	11537412	
7788291	8042169	8484741	8838965	9699207	10439990	11068569	11546375	
7836267	8050251	8527549	8843612	9755988	10542572	11074088	11558419	

Contrat de Licence Logiciel

Le logiciel de Barracuda Networks est fourni sous licence par Barracuda Networks, Inc. et d'autres donneurs de licences, certains des programmes faisant partie du logiciel pouvant être concédés sous GPL (GNU General Public License) ou LGPL (Lesser General Public License). Conformément aux conditions de la GPL et de la LGPL, vous pouvez demander une copie du code source. Cette offre est valable pour 3 ans maximum à partir de la date de l'achat d'origine du produit. Pour des informations supplémentaires et des informations sur les licences applicables, veuillez contacter Barracuda Networks à l'adresse suivante: contact@barracuda.com

Les termes du contrat de licence logiciel Barracuda Networks sont disponibles à l'adresse suivante: <https://www.barracuda.com/legal/software-license-agreement>

Garantie

Les conditions de garantie du matériel et du logiciel sont disponibles à l'adresse suivante: <https://www.barracuda.com/legal/warranty>

Conformité en Matière D'exportation

Barracuda Networks s'engage à respecter entièrement la législation officielle et la réglementation américaines et des pays hôtes, y compris les lois d'importation et d'exportation. Toute personne physique ou morale exportant ou ré-exportant des produits de Barracuda Networks directement ou indirectement et par quelque moyen que ce soit, y compris par transfert électronique, est tenue de le faire entièrement en conformité avec les réglementations américaines en matière d'exportation et les lois des pays hôtes et doit obtenir et mettre à jour toutes les approbations et licences des autorités gouvernementales compétentes. La législation américaine en matière d'exportation limite l'expédition de produits aux pays frappés d'embargo et aux personnes physiques ou morales faisant l'objet d'une interdiction. Pour des informations supplémentaires sur les lois américaines d'exportation, veuillez visiter le site <http://www.bis.doc.gov>.

Afin de vous aider à remplir vos obligations au niveau de la conformité en matière d'exportation, Barracuda Networks met à disposition un tableau de classement des exportations de produits à l'adresse suivante: www.barracuda.com/tradecompliance.

Pour toute question de la part de votre entreprise sur cette obligation ou nos politiques de conformité commerciale, veuillez contacter votre Barracuda Networks Channel Account Manager ou envoyer un e-mail à TradeCompliance_Team@barracuda.com.



Sicurezza Elettrica

Seguire queste precauzioni base di sicurezza in ambito elettrico per evitare lesioni e proteggere il dispositivo da danni:

- Prestare attenzione alle sedi degli interruttori di alimentazione sul telaio del dispositivo, all'interruttore di arresto di emergenza dell'area di alloggiamento, all'interruttore di disconnessione e alla presa elettrica. In questo modo sarà possibile eliminare rapidamente l'energia elettrica dal sistema in caso di incidente elettrico.
- Non lavorare da soli su componenti ad alta tensione.
- Al momento di lavorare su circuiti elettrici scoperti, è richiesta la presenza di un'altra persona esperta in ambito di controlli di spegnimento per disattivare la corrente in caso di necessità.
- Utilizzare una sola mano al momento di lavorare su strumentazione elettrica collegata. In questo modo si evita la creazione di un circuito completo, il quale potrebbe provocare shock elettrico. Prestare particolare attenzione agli utensili metallici, i quali possono facilmente danneggiare i componenti elettrici o le schede elettroniche in caso di contatto con esse.
- Non utilizzare tappetini per la riduzione della scarica elettrostatica come protezione da shock elettrico. Utilizzare invece tappetini di gomma appositamente studiati per l'isolamento elettrico.
- Il cavo dell'alimentatore deve essere dotato di connettore di terra ed essere inserito in prese elettriche con messa a terra.
- Per evitare incendi o rischio di shock non esporre l'unità a pioggia o umidità, né installare il prodotto in prossimità di acqua.
- Evitare di installare il prodotto durante i temporali.
- Assicurarsi che le prese dell'aria (aperture poste lungo i lati e sul retro) siano sempre libere e che vi sia sufficiente ricambio d'aria al loro interno per evitare il surriscaldamento.

Sicurezza Generale

- L'area intorno al dispositivo deve essere pulita e sgombra.
- Individuare una posizione sicura e asciutta per collocare il prodotto, tenendolo a distanza da superfici/aree circostanti umide.
- Al momento di operare sul sistema non indossare indumenti svolazzanti quali cravatte e maniche di camicia sbottonate, i quali possono entrare in contatto con i circuiti elettrici o restare impigliati nelle ventole di raffreddamento.
- Rimuovere gioielli o oggetti di metallo indossati, i quali possono rivelarsi ottimi conduttori di metallo e creare così corto circuito, provocando lesioni in caso di contatto con circuiti stampati o aree sotto tensione.
- Nel caso di strumentazione alimentata da rete elettrica, la presa elettrica deve essere installata in prossimità della strumentazione ed essere facilmente accessibile.

Precauzioni da Scarica Elettrostatica

Una scarica elettrostatica (ESD) è generata da oggetti con cariche elettriche differenti che vengono in contatto tra loro. Una scarica elettrica, la quale può danneggiare i componenti elettronici e i circuiti stampati, neutralizza tale differenza.

- Utilizzare un bracciale antistatico progettato per prevenire la scarica statica.
- Conservare tutti i componenti e i circuiti stampati (PCB) nelle proprie sacche antistatiche fino al momento dell'uso.
- Toccare un oggetto di metallo messo a terra prima di rimuovere la scheda dalla sacca antistatica.
- I componenti o i PCB non devono entrare in contatto con gli indumenti, poiché potrebbe crearsi una carica nonostante si indossi il bracciale.
- La scheda va maneggiata tenendola solo dai bordi: non toccare i componenti, moduli di memoria periferica o contatti.
- Al momento di maneggiare chip o moduli, evitare di toccare i pin.
- Rimettere la scheda server e le periferiche nelle sacche antistatiche se non in uso.
- Per motivi di messa a terra, assicurarsi che il telaio del computer offra eccellente conducibilità tra alimentazione, case, fissaggi di montaggio e scheda server.
- Dopo l'accesso all'interno di un sistema, richiudere il medesimo e assicurarlo all'unità rack con le viti di fissaggio, una volta verificato che tutte le connessioni siano state eseguite.

Brevetti Stati Uniti

Questo prodotto Barracuda Networks è coperto da uno o più dei seguenti brevetti statunitensi:

7010611	7861300	8069244	8555365	8849836	9871817	10574676	11126417	11563757
7093287	7877789	8122493	8559450	8977661	9881271	10623441	11134058	
11588724								
7093294	7898953	8204948	8571042	9021017	9918346	10761825	11145221	11645943
7103913	7917756	8219644	8725704	9152466	9942050	10778714	11159565	11665195
7149222	7917943	8280895	8726384	9195668	10044677	10778717	11250130	
11750647								
7149795	7930428	8285997	8775604	9224117	10050795	10834129	11356469	
7254038	7970899	8434140	8788597	9262643	10083307	10860715	11457040	
7272155	7974288	8443193	8788831	9373001	10171582	10958662	11463409	
7328247	7987267	8447856	8789178	9465598	10333709	11025655	11463460	
7688815	7996475	8463797	8831030	9680818	10404726	11050714	11537412	
7788291	8042169	8484741	8838965	9699207	10439990	11068569	11546375	
7836267	8050251	8527549	8843612	9755988	10542572	11074088	11558419	

Licenza Software

Barracuda Networks software è fornito dietro licenza da Barracuda Networks, Inc. e altri licenziatari e alcuni dei programmi compresi nel software possono essere forniti dietro licenza GNU General Public License (GPL) o Lesser General Public License (LGPL). In accordo con i termini delle licenze GPL e LGPL è possibile richiedere una copia del codice sorgente necessario. Questa offerta è valida per tre anni dalla data di acquisto originale del prodotto. Per dettagli e informazioni sulle licenze applicabili è possibile contattare Barracuda Networks a contact@barracuda.com.

I termini delle licenze software Barracuda Networks sono indicati in:

<https://www.barracuda.com/legal/software-license-agreement>.

Garanzia

L'hardware e il software sono coperti da garanzia come indicato nella garanzia presente in:

<https://www.barracuda.com/legal/warranty>

Conformità All'esportazione

Barracuda Networks si impegna a rispettare in toto le leggi e le normative del Governo USA e quelle del Paese ospitante, ivi comprese le leggi in materia di importazione ed esportazione. Qualsiasi persona o entità che esporti o ri-esporti i prodotti di Barracuda Networks direttamente o indirettamente e con qualunque mezzo, compreso il trasferimento elettronico, è completamente responsabile della sua esecuzione in accordo con le Normative per l'Amministrazione delle Esportazioni degli Stati Uniti e le leggi dei Paesi ospitanti, e dovrà ottenere e mantenere tutti i permessi e le licenze dalle rispettive autorità governative. Le leggi USA sulle esportazioni vietano il trasporto del prodotto in Paesi sottoposti a embargo e a persone/entità soggette a restrizioni. Per dettagli relativi alle leggi USA sulle esportazioni vedere <http://www.bis.doc.gov>.

Per consentire il rispetto degli obblighi in materia di conformità sulle esportazioni, Barracuda Networks offre una griglia di classificazione per l'esportazione dei prodotti all'indirizzo: www.barracuda.com/tradecompliance.

Qualora la propria organizzazione abbia domande relative a tale obbligo o alle nostre politiche di conformità in ambito commerciale, si prega di contattare il Barracuda Networks Channel Account Manager competente o inviare una e-mail all'indirizzo TradeCompliance_Team@barracuda.com.



Elektrik Güvenliđi

Kendinizi korumak ve cihaza zarar gelmesini önlemek için elektrikle ilgili aşağıda belirtilen temel güvenlik önlemlerini alın:

- Cihaz kasası üzerindeki elektrik anahtarının, muhafaza için acil güç kapama anahtarının, bağlantı kesme anahtarının ve elektrik prizinin yerini iyi öğrenin. Bu sayede elektrik arızası oluşması halinde sistemin elektrikliğini en hızlı şekilde kesebilirsiniz.
- Yüksek voltajlı bileşenler üzerinde tek başınıza çalışmayın.
- Çıplak elektrik devreleriyle çalışırken gerekli durumlarda elektrikliğini kesmek için deneyimli bir kişinin yakınlarında olması gerekir.
- Elektrikle ilgili ekipmanlar üzerinde çalışırken yalnızca tek elinizi kullanın. Bu sayede devrenin tamamlanmasını önleyerek elektrik şokuna karşı koruma sağlayabilirsiniz. Elektrikli bileşenlere veya devre kartlarına temas ettiğinde kolayca zarar verebileceğinden metal aletlerle çalışırken çok dikkatli olun.
- Elektrik şoklarından koruma amacıyla elektrostatik boşalmayı azaltmak üzere tasarlanmış paspasları kullanmayın. Bunun yerine elektrik yalıtımı için tasarlanmış kauçuk paspasları kullanın.
- Elektrik kablosunda topraklı fiş olması ve topraklı prize bağlanması gerekir.
- Yangın veya şok tehlikesini önlemek için cihazı yağmura veya neme maruz bırakmayın, suya yakın yerlere monte etmeyin.
- Yıldırım düşmesi tehlikesine karşı fırtınalı havalarda ürünü monte etmeyin.
- Hava kanallarının (yanlarda ve arkadaki açıklıklar) engellenmediğinden ve kanallardan aşırı ısınmayı önlemeye yetecek kadar hava akışı sağlandığından emin olun.

Genel Güvenlik

- Cihaz çevresindeki alanı temiz tutun ve dađınık bırakmayın.
- Bu ürünü güvenli ve kuru bir yere yerleştirin. ıslak yüzeylerden/yerlerden uzakta tutun.
- Sistem üzerinde çalışırken kravat ve iliklenmemiş gömlek kolları gibi elektrik devreleriyle kondağa geçebilecek veya sođutma fanlarına çekilebilecek nitelikte kıyafetler giymeyin.
- Varsa üzerinizdeki mücevherleri ve metal nesnelere çıkarın. Bu nesnelere metal iletken görevi görerek kısa devre oluşturabilir, devre kartları veya elektrik bulunan alanlara temas ederse zarar verebilir.
- Cihazın bağlandığı priz cihaza yakın ve kolay erişilebilir olmalıdır.

Elektrostatik Boşalma Önlemleri

Elektrostatik boşalma (ESD), farklı elektrik yüklerine sahip iki nesnenin birbiriyle temasa geçmesinden kaynaklanır. İki yük arasındaki farkı sıfırlamak için ortaya çıkan elektrik boşalması, elektronik bileşenlere ve baskılı devre kartlarına zarar verebilir.

- Statik boşalmayı önlemek için üretilmiş topraklı bileklikleri kullanın.
- Tüm bileşenleri ve baskılı devre kartlarını (PCB) kullanıma hazır olana kadar antistatik poşetlerinden çıkarmayın.
- Kartı antistatik poşetinden çıkarmadan önce topraklanmış bir metale dokununuz.
- Bileşenlerin veya baskılı devre kartlarının kıyafetinize temas etmesine izin vermeyin. Bileklik kullandıktan sonra dahi yüklenme oluşabilir.
- Kartı yalnızca kenarlarından tutunuz. Üzerindeki bileşenlere, bellek modüllerine veya uçlarına dokunmayınız.
- Yongalar veya modüllerle çalışırken pinlerine dokunmamaya dikkat ediniz.
- Sunucu kartını ve çevre birimlerini kullanılmadığı zamanlarda antistatik poşetlerine koyunuz.
- Topraklama için bilgisayarınızın kasaasının güç kaynağı, kasa, sabitleyiciler ve sunucu kartı arasında tam iletkenlik sağlandığından emin olun.
- Sistemin içini açıp çalıştıktan sonra tekrar kapatın, rafa sabitleyin ve tüm bağlantıların yapıldığından emin olun.

Birleşik Devletler Patentleri

Bu Barracuda Networks ürünü aşağıdaki ABD patentlerinden biri veya daha fazlası kapsamındadır:

7010611	7861300	8069244	8555365	8849836	9871817	10574676	11126417	11563757
7093287	7877789	8122493	8559450	8977661	9881271	10623441	11134058	
11588724								
7093294	7898953	8204948	8571042	9021017	9918346	10761825	11145221	11645943
7103913	7917756	8219644	8725704	9152466	9942050	10778714	11159565	11665195
7149222	7917943	8280895	8726384	9195668	10044677	10778717	11250130	
11750647								
7149795	7930428	8285997	8775604	9224117	10050795	10834129	11356469	
7254038	7970899	8434140	8788597	9262643	10083307	10860715	11457040	
7272155	7974288	8443193	8788831	9373001	10171582	10958662	11463409	
7328247	7987267	8447856	8789178	9465598	10333709	11025655	11463460	
7688815	7996475	8463797	8831030	9680818	10404726	11050714	11537412	
7788291	8042169	8484741	8838965	9699207	10439990	11068569	11546375	
7836267	8050251	8527549	8843612	9755988	10542572	11074088	11558419	

Yazılım Lisansı

Barracuda Networks yazılımı, Barracuda Networks, Inc. ve diğer lisans sahiplerinin lisanslarıyla sunulmaktadır. Yazılım içindeki programlar GNU Gen-eral Public License (GPL) veya Lesser General Public License (LGPL) çerçevesinde sunuluyor olabilir. GPL ve LGPL şartları uyarınca ilgili kaynak kodların bir kopyasını talep edebilirsiniz. Bu teklif ürünün ilk satın alma tarihinden itibaren üç yıl boyunca geçerlidir. İlgili lisanslar hakkında ayrıntılı bilgi için lütfen Barracuda Networks ile iletişime geçin: contact@barracuda.com.

Barracuda Networks yazılımı lisans şartları şu adreste yer almaktadır: <https://www.barracuda.com/legal/software-license-agreement>.

Garanti

Donanım ve yazılım, şu adreste yer alan garanti şartları çerçevesinde garanti altına alınmıştır: <https://www.barracuda.com/legal/warranty>.

İhracata Uygunluk

Barracuda Networks, ihracat ve ithalat yasaları dahil olmak üzere ABD ve ev sahibi ülkelerin yasalarına uygunluk konusunda bağlılık göstermektedir. Barracuda Networks ürünlerini elektronik transfer dahil olmak üzere herhangi bir şekilde doğrudan veya dolaylı olarak ihraç veya ithal eden kişi veya kurumlar, faaliyetlerini ABD İhracat Yönetimi Düzenlemeleri ve ev sahibi ülkelerin yasaları çerçevesinde yürütmekten sorumlu olacaktır ve bu kişi veya kuruluşların ilgili devlet kurumlarından gerekli tüm onayları ve lisansları alması zorunludur. ABD ihracat yasaları ürünün ambargo uygulanan ülkelerin yanı sıra reddedilmiş kişi veya kurumlara gönderilmesini kısıtlamaktadır. ABD ihracat yasaları hakkında ayrıntılı bilgi için lütfen şu adresi ziyaret edin: <http://www.bis.doc.gov>.

Barracuda Networks, ihracata uygunluk konusundaki yükümlülüklerinizi yerine getirmenize destek olmak amacıyla şu adreste bir ürün ihracat sınıflandırması tablosu sunmaktadır: www.barracuda.com/tradecompliance.

Kuruluşunuzun bu yükümlülük veya ticari uygunluk politikalarımız hakkında soruları olması halinde lütfen Barracuda Networks Kanal Hesap Yöneticisi ile iletişime geçin veya şu adrese e-posta gönderin: TradeCompliance_Team@barracuda.com.



電源周りの安全性

電気関連の安全性に関する注意に従い、危険から身を守り、デバイスが損傷を受けないようにします。

- ・ デバイスのシャーシの電源スイッチ、部屋の緊急電源スイッチ、切断スイッチ、電源コンセントの場所を確認してください。確認しておくことで、システムから電源を素早く取り除き、電源周りの事故の発生を防ぐことができます。
- ・ 高電圧のコンポーネントを使用して作業する場合は、一人で作業しないようにしてください。
- ・ 露出している電源回路の周辺で作業を行う場合には、必要に応じて電源をオフできるように、電源制御について把握している人の近くで作業を行うようにしてください。
- ・ 電源がついている電源装置で作業をする場合は、片手で作業するようにしてください。こうすることで、閉回路（電気ショックが発生する可能性がある）にならないようにします。金属工具を使用する場合は細心の注意を払うようにしてください。金属工具が電気パーツや回路基板に触れると簡単に損傷してしまいます。
- ・ 電気ショックから身を守るために静電気放電(ESD)用のマットを使用しないでください。代わりに、電気絶縁体用に設計されたゴムマットを使用するようにしてください。
- ・ 電源コードには接地コンセントが含まれており、必ず接地極付コンセントに接続するようにしてください。
- ・ 火災や電気ショックが発生しないように、雨や湿気に装置が降れないようにし、本製品を水気の近くに設置しないようにしてください。
- ・ 雷雨発生時には、本製品を設置しないようにしてください。
- ・ 換気口（横および背部）が遮断されないようにし、換気口への空気の流れを確保して デバイスの過熱を防ぎます。

安全性について

- ・ デバイスの周辺は清潔に保ち、ごみなどがいない状態にします。
- ・ 安全で乾燥した場所に本製品を設置します。湿気のある箇所／エリアには設置しないでください。
- ・ システムで作業する際は、ネクタイやシャツの袖のボタンが留められていないものなどゆったりした衣服を着用しないようにしてください。これらの衣服が電気回路に降れたり、冷却ファンに引きこまれたりする可能性があります。
- ・ ジュエリーや金属関連のものは着用しないようにしてください。金属導体として機能し、ショートしたり、印刷回路基板または電源部分に触れた場合に怪我をしたりする可能性があります。
- ・ 差し込み装置については、装置の近くに壁コンセントを設置して簡単にアクセスできるようにします。

静電気放電に関する注意

静電気放電 (ESD) は、2 つの異質の電荷が接触することで発生します。静電気放電はこの違いを中和させますが、電気コンポーネントおよび印刷回路基板に損傷を与える可能性があります。

- ・ 静電気放電を予防する接地抵抗タイプのリストバンドを使用するようにしてください。
- ・ 使用の準備ができるまで、すべてのコンポーネントおよび印刷回路板 (PCB) は帯電防止袋に入れておくようにしてください。
- ・ 接地している金属体に触れてから、帯電防止袋から回路版を取り出します。
- ・ コンポーネントまたはPCBが着用している衣服に触れないようにしてください。リストバンドを着用していても、電気が発生してしまう可能性があります。
- ・ 基板は末端のみを取り扱うようにしてください。コンポーネント、周辺メモリーモジュールまたはコンタクトに触れないようにしてください。
- ・ チップまたはモジュールを取り扱い際には、ピンに触れないようにしてください。
- ・ 使用時以外は、サーバーボードおよび周辺機器を帯電防止袋に入れておいてください。
- ・ 接地の目的で、お使いのコンピューターシャーシにより、電源、ケース、固定ファスナー、サーバーボードの間で優れた伝導性が提供されるようにしてください。
- ・ システム内部にアクセスした後、すべての接続が完了してからシステムバックアップを閉じ、固定ネジでラック装置を固定してください。

米国特許

このバラクーダ製品は下記の1件以上の米国特許の対象です。

7010611	7861300	8069244	8555365	8849836	9871817	10574676	11126417	11563757
7093287	7877789	8122493	8559450	8977661	9881271	10623441	11134058	
11588724								
7093294	7898953	8204948	8571042	9021017	9918346	10761825	11145221	11645943
7103913	7917756	8219644	8725704	9152466	9942050	10778714	11159565	11665195
7149222	7917943	8280895	8726384	9195668	10044677	10778717	11250130	
11750647								
7149795	7930428	8285997	8775604	9224117	10050795	10834129	11356469	
7254038	7970899	8434140	8788597	9262643	10083307	10860715	11457040	
7272155	7974288	8443193	8788831	9373001	10171582	10958662	11463409	
7328247	7987267	8447856	8789178	9465598	10333709	11025655	11463460	
7688815	7996475	8463797	8831030	9680818	10404726	11050714	11537412	
7788291	8042169	8484741	8838965	9699207	10439990	11068569	11546375	
7836267	8050251	8527549	8843612	9755988	10542572	11074088	11558419	

ソフトウェアライセンス

Barracuda Networks ソフトウェアは、Barracuda Networks, Inc. および他のライセンス提供者のライセンスに基づき提供されています。またこのソフトウェアに含まれるプログラムの一部は、GNU General Public License (GPL) または Lesser General Public License (LGPL)をベースに提供されている場合があります。GPL および LGPL の条件に従い、該当するソースコードのコピーを依頼する場合があります。このライセンスは、本製品の購入日から3年間有効です。適切なライセンスに関する情報はBarracuda Networks (contact@barracuda.com) までお問い合わせください。

Barracuda Networks ソフトウェアライセンスの条件は、以下のURLを参照してください。<https://www.barracuda.com/legal/software-license-agreement>

保証

以下のURLにある保証にて記載されている内容どおりに、ハードウェアおよびソフトウェアは保証されるものとします。<https://www.barracuda.com/legal/warranty>

輸入に関するコンプライアンス

Barracuda Networks は、輸出入法を含む、US政府および現地法および規則に完全準拠するように努めています。Barracuda Networks の製品を直接的または間接的、および電信などあらゆる手段で輸出または再輸出する個人または法人は、米国輸出管理規制および現地法に準拠し、適切な自治体から承認またはライセンスを取得して保持するものとします。US輸出法では、輸出入を禁止する国および人または法人への製品の出荷を制限しています。US 輸出法に関する詳細は <http://www.bis.doc.gov>を参照してください。

輸出コンプライアンスに関する責務を果せるように、Barracuda Networks は、以下のURLで製品輸出区分の表を提供しています。www.barracuda.com/tradecompliance

本義務または貿易コンプライアンスポリシーについてご質問がある場合は、Barracuda Networks チャンnelアカウンタマネージャーにお問い合わせいただくか、TradeCompliance_Team@barracuda.comまでメールでご連絡ください。





Copyright 2018—2025 Barracuda Networks, Inc.
3175 S. Winchester Blvd., Campbell, CA 95008
408-342-5400/888-268-4772 (US & Canada)
barracuda.com

v12.3-01-12262025