

AWS Reference Architecture - CloudGen Firewall Auto Scaling Cluster

<https://campus.barracuda.com/doc/79462692/>

Protecting highly dynamic AWS resources with a static firewall setup is neither efficient nor economical. A CloudGen Firewall Auto Scaling Cluster scales with demand, thereby creating a cost-effective, robust solution for securing and connecting to your cloud resources. The firewall cluster can be deployed either to integrate with existing resources in an AWS region, or as part of an auto scaling application. Both options offer an integrated Barracuda Web Application Firewall (WAF) as a second security tier. The firewall cluster integrates tightly with AWS services and APIs. Configuration changes are synchronized securely over the AWS backend, with all instances sharing the same configuration. The admin can configure the changes like a single firewall instance. The firewall cluster is highly available and scalable over multiple AWS Availability Zones, without any single point of failure such as additional management or worker node instances. The firewall cluster uses the PAYG image of the Barracuda CloudGen Firewall in the AWS Marketplace. This allows you to quickly deploy without the need for long-term licensing commitments. CloudGen Firewall clusters cannot be managed by a Firewall Control Center.

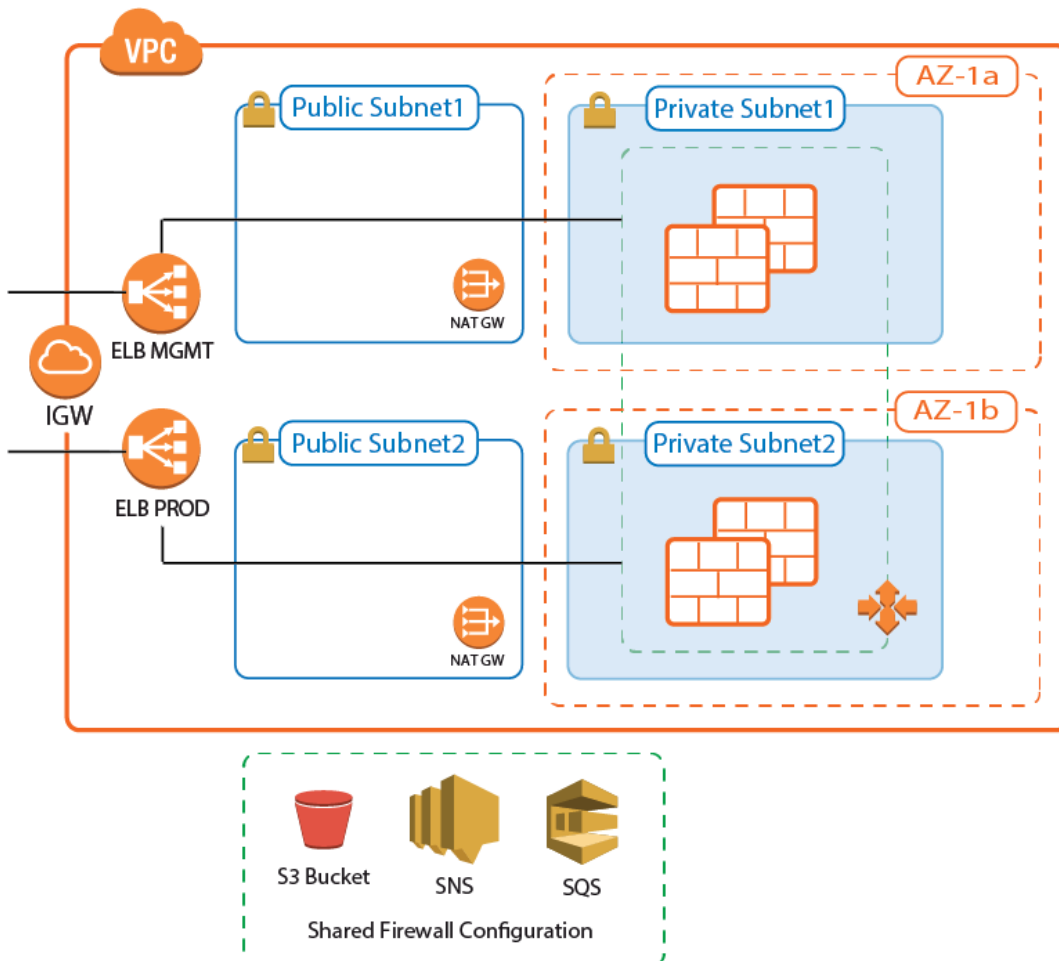

Use Cases for a CloudGen Firewall Auto Scaling Cluster

- **Secure Remote Access** – Client-to-site VPN, CudaLaunch, and SSL VPN using the TINA VPN protocol.
- **Edge Firewall** – Scan for malicious traffic using the built-in IPS and handle access to resources via access rules.

AWS Architectures for CloudGen Firewall Auto Scaling Clusters

Since there are no external dependencies, the CloudGen Firewall cluster can either be used as a drop-in solution to protect your existing applications in the same AWS region, or it can be included as part of the architecture of your application.

Transit VPC with VPC Peering

The firewall cluster is used in a Transit VPC configuration. The firewall VPC acts as a hub securing all traffic in and out of the peered VPCs. Two peered VPCs must be in the same AWS region, but can be in different AWS accounts. Transitive peering is not possible; therefore, resources in two VPCs both peered with the Transit VPC cannot communicate with each other. Incoming traffic is handled via access rules allowing access to the backend resources based on the access rule matching criteria, such as source, user, or time. Since the VPC for the firewall cluster is separated from the VPCs containing the applications, rapid iteration of the applications is possible without requiring changes to the firewall cluster. For example, in a typical scenario with production, engineering, and development VPCs, granular access rules allow the firewall admin to separate users based on their role:

- Traffic to production VPCs is secured by IPS and, optionally, forwarded to a Web Application Firewall cluster.
- QA and developers log in via client-to-site VPN. The firewall uses the user information to allow access only to their respective VPCs.
- Admins are in a special group, allowing them backend access to production and QA VPCs.

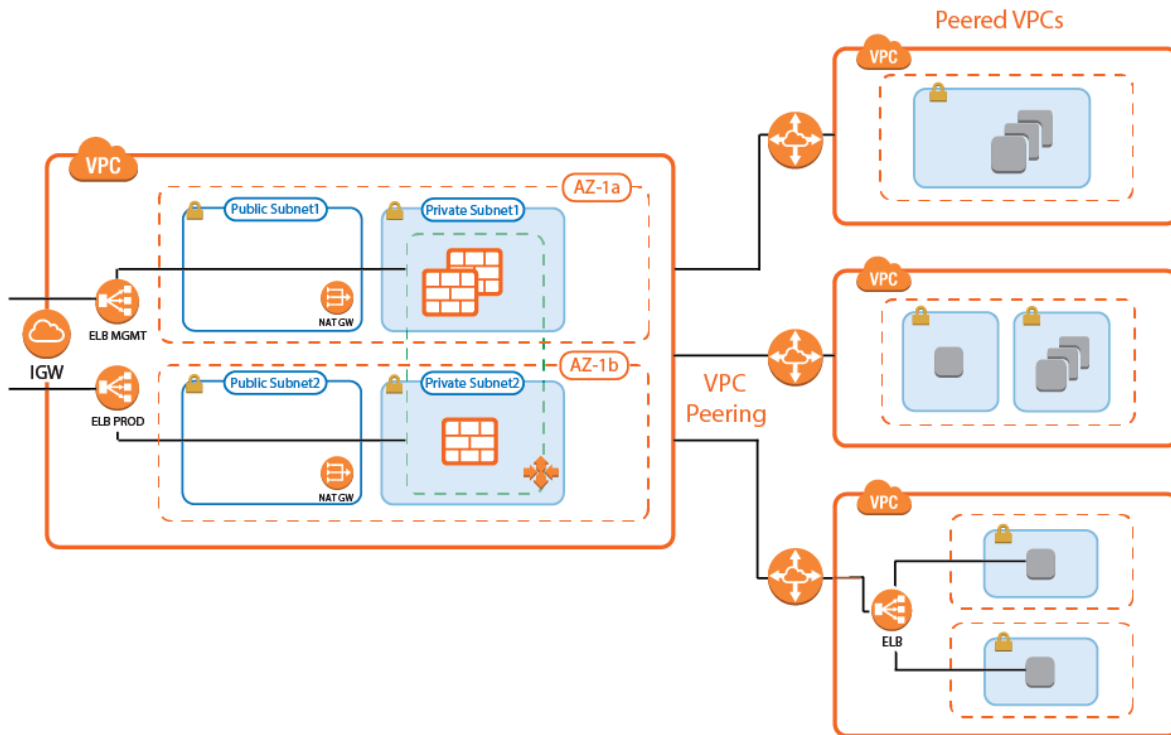

Transit VPC with VPC Peering and Barracuda Web Application Firewall Auto Scaling Cluster

A variation of the transit VPC includes an additional Web Application Firewall cluster behind the CloudGen Firewall cluster. The Barracuda Web Application Firewall and CloudGen Firewall F can work in tandem to block IP addresses from which malicious activity was detected. Whereas the WAF is very good at detecting application layer attacks, the CloudGen Firewall is more efficient on the network layer. Connections blocked by the firewall IPS are never forwarded to the WAF, thereby freeing resources that would otherwise have to be used to block known-bad connections.

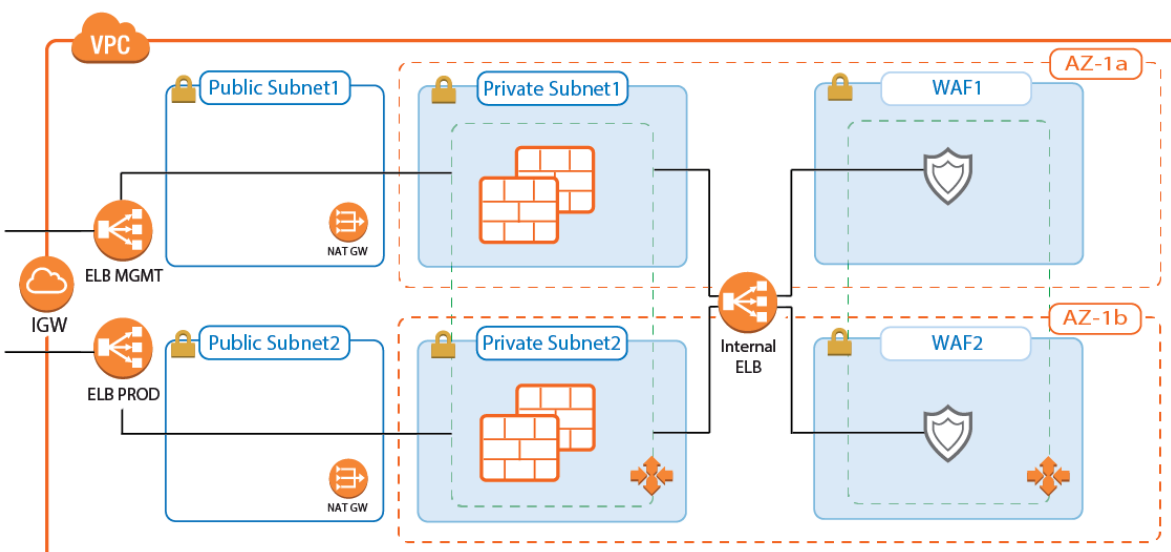

Integration into AWS Architecture

You can integrate the firewall cluster into your existing architecture. Use the default CloudFormation template as reference. To be able to reuse the configuration, configure the CloudGen Firewall cluster one time via Barracuda Firewall Admin, and then replicate the S3 bucket to reuse the configuration.

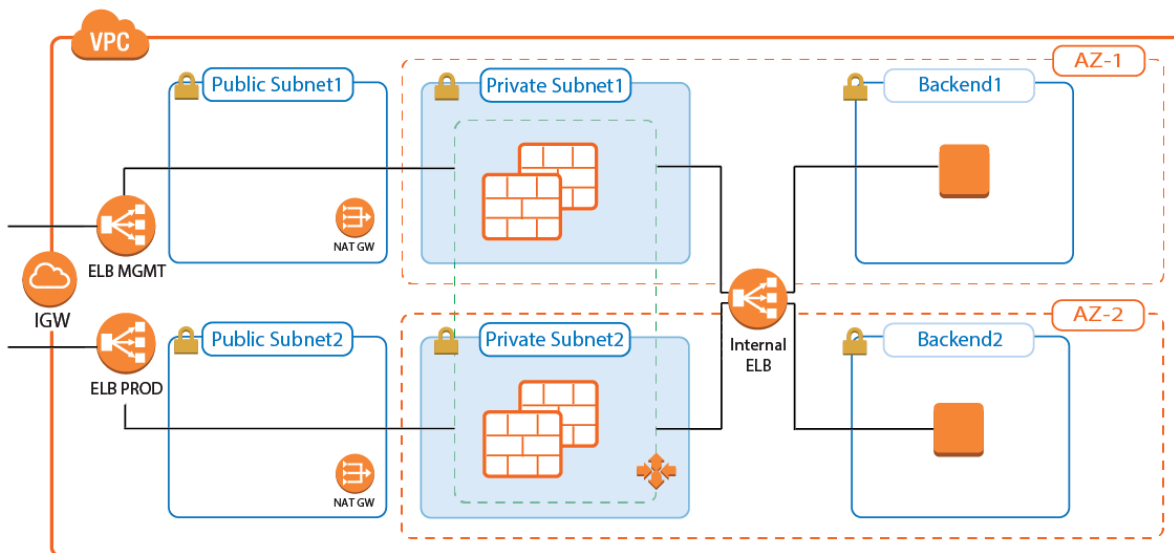

Deploying a CloudGen Firewall Auto Scaling Cluster

The firewall cluster must be deployed via CloudFormation template. The template deploys a VPC with public and private subnets in two Availability Zones. In the private subnets, the firewall cluster is deployed. In the public subnets, the Elastic Load Balancer (ELB) and two NAT gateways are deployed (one for each Availability Zone). The NAT gateways are required for the firewalls to be able to access the AWS backend. APIs are required to enable the secure configuration sync over the AWS backend.

1. Create an IAM role for the firewall cluster. For step-by-step instructions, see [How to Create an IAM Role for a CloudGen Firewall in AWS](#).
2. Download the **NGF_Autoscaling.json** template and parameter file from the Barracuda Network GitHub account: <https://github.com/barracudanetworks/ngf-aws-templates/tree/master/ASG>.
3. Accept the Software Terms for the **Barracuda CloudGen Firewall PAYG** image in the AWS Marketplace.
4. Create a parameter template file containing your parameters values.
5. Deploy the **autoscale.json** CloudFormation template via AWS CLI or AWS console.

```
aws cloudformation create-stack --stack-name "YOUR_STACK_NAME" --
template-body YOUR_S3_BUCKET/NGF_Autoscaling.json --parameter
YOUR_S3_BUCKET/NGF_Autoscaling_parameters.json
```

During deployment, the following resources are created by the template:

- VPC with private and public subnets in two Availability Zones.
- Two ELBs: one for management connections, the other for VPN and SSL VPN services.
- One S3 bucket.
- Automatically created SNS and SQS queues.
- Two NAT gateways.
- A Launch Configuration and Auto Scaling group for the firewall. The Barracuda CloudGen Firewall PAYG image must be used.
- Scaling policies using the number of client-to-site VPN tunnels.

After stack creation is complete, the FQDN of the ELB are listed in the **Output** tab.

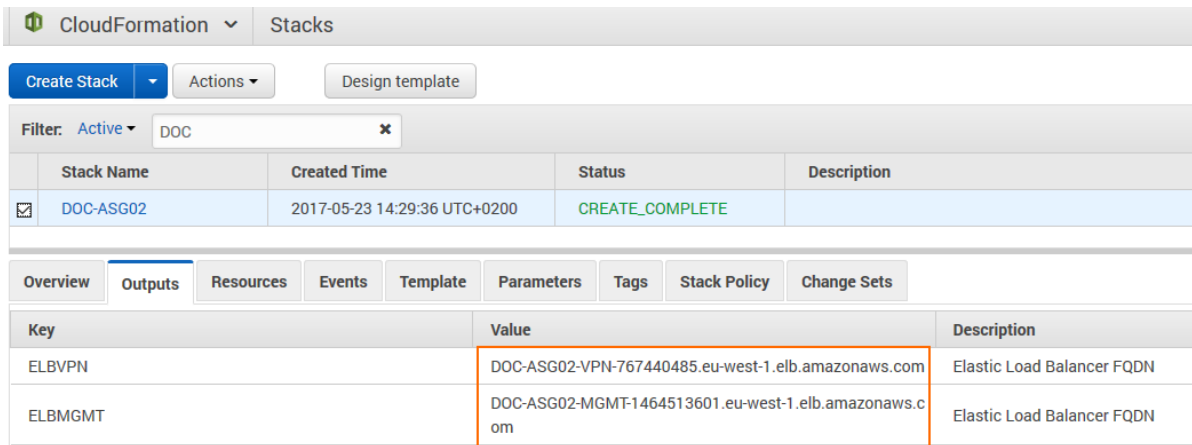

Stack Name	Created Time	Status	Description
<input checked="" type="checkbox"/> DOC-ASG02	2017-05-23 14:29:36 UTC+0200	CREATE_COMPLETE	

Key	Value	Description
ELBVPN	DOC-ASG02-VPN-767440485.eu-west-1.elb.amazonaws.com	Elastic Load Balancer FQDN
ELBMGMT	DOC-ASG02-MGMT-1464513601.eu-west-1.elb.amazonaws.com	Elastic Load Balancer FQDN

For step-by-steps instructions, see [How to Deploy a CloudGen Firewall Auto Scaling Cluster in AWS](#).

Remote Access

Remote Access features offer remote users secure access to their organization's cloud applications and resources from virtually any device. Depending on the type of access users require, they can choose between the full client-to-site VPN or the SSL VPN web portal.

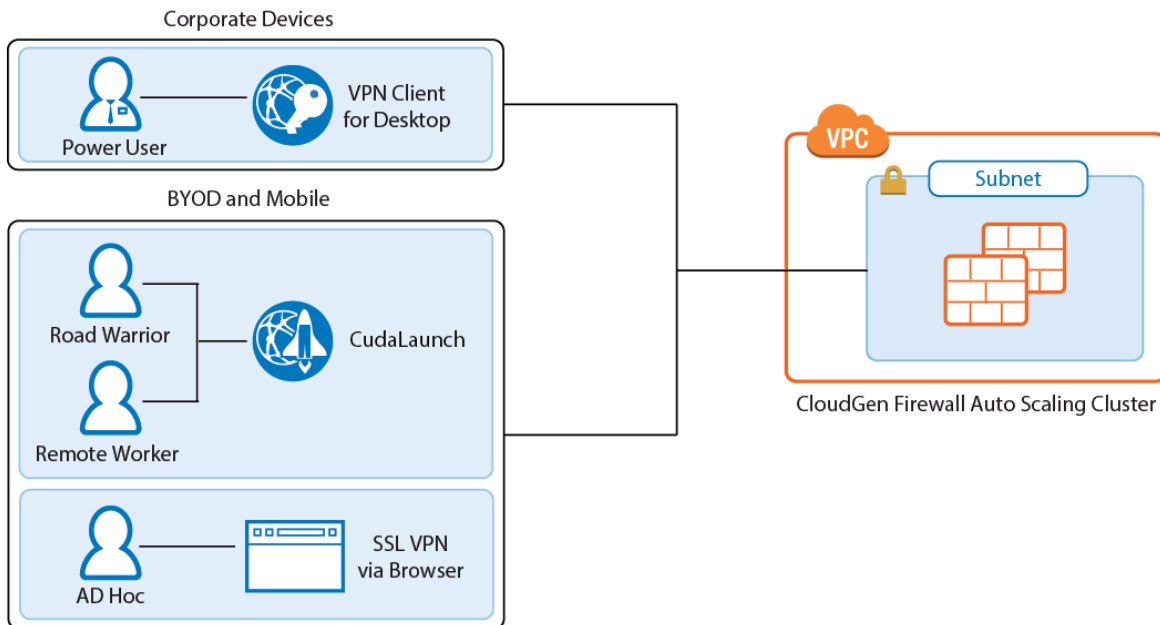

Client-to-Site VPN

The client-to-site VPN uses the TINA VPN protocol on TCP port 691 to connect to the firewall cluster. TINA is designed to overcome limitations imposed by the IPsec protocol and offers immunity to NAT devices or proxies, heartbeat monitoring, and fast failover support. VPN clients can be authenticated through client certificates, external and internal authentication schemes, or a combination thereof. Supported VPN clients are:

- **Barracuda VPN / NAC Client** for Windows, macOS, Linux, and OpenBSD.
- **CudaLaunch** for Windows, macOS, iOS, and Android version 2.3.0 or higher.

On the CloudGen Firewall Auto Scaling Cluster, configure the VPN service for client-to-site connections by adding one or more VPN group policies. Incoming client-to-site connections are matched to a VPN group policy based on the group policy condition. The first matching VPN group policy is chosen. VPN group policy conditions allow you to define the following criteria:

- Group patterns from external authentication schemes
- X.509 certificate conditions
- VPN clients
- Source IP address or network for the VPN clients

Edit Group Policy ✕

Name: Disabled

Common Settings C2NetworkPolicy

Statistic Name:

Network C2SNetwork 172.16.0.0

DNS:

WINS:

Network Routes:

Network Routes
0.0.0.0/0

Access Control List (ACL):

Access Control List

Barracuda - Settings: C2NetworkPolicy

- Enforce Windows Security Settings (Vista and newer o...**
- VPN Client Network**

DNS Suffix for VPN	
ENA	No
Always On	No
- Firewall Rules**

VPN Client NAC	Ignore
VPN	
Offline	
Firewall Always ON	No
- Login Message**

Message	
Bitmap	

Group Policy Condition

External Group	Client	X509 Subject	Cert Policy / OID	Peer
*	Phion , IPsec , Tr. Agent	X509 Subject emailAddress=e...	Cert Policy / OID / =	Peer

Export to file ...

For step-by-step instructions, see [How to Configure a Client-to-Site VPN Group Policy for an CloudGen Firewall Auto Scaling Cluster in AWS.](#)

SSL VPN and CudaLaunch

The SSL VPN service provides seamless integration without having to install a client app. For a richer level of remote access, CudaLaunch works with the SSL VPN service to provide more advanced SSL VPN features such as SSL tunneling or native app support. The number of simultaneous users using the SSL VPN is limited only by the performance and number of firewall instances in the Auto Scaling group. Since the SSL VPN service is not designed to share session information between the members of the Auto Scaling group, the ELB must be configured to use sticky sessions and SSL offloading to ensure that the individual client will always be redirected to the same firewall instance. SSL VPN resources can be accessed by the following clients:

- **CudaLaunch**
- **SSL VPN web interface** - All modern browsers.

For step-by-step instruction, see [How to Configure the SSL VPN Services for AWS Auto Scaling Clusters.](#)

Firewall and IPS

The firewall cluster secures incoming and outgoing traffic from your AWS resources. This can be traffic from AWS instances in peered VPCs or instances in the private networks of the VPC. If enabled on the access rule matching the traffic, the IPS engine on the firewall continuously compares the packet stream with the internal signatures database for malicious code patterns. If malicious packets are identified, traffic is either reported or dropped, depending on the configuration of the IPS. To ensure that the latest patterns are used, the IPS patterns are updated automatically from the Barracuda download servers.

When used in combination with a Barracuda Web Application Firewall cluster, the IPS and access rules block network layer attacks, saving processing power on the WAF for layer 7 attacks. For traffic to be able to flow through the firewall cluster and back, all access rules must use both source and destination IP address translation (NAT). This ensures that traffic will go back over the same firewall. The CloudGen Firewall Auto Scaling Cluster cannot be used as the default gateways for your AWS resources.

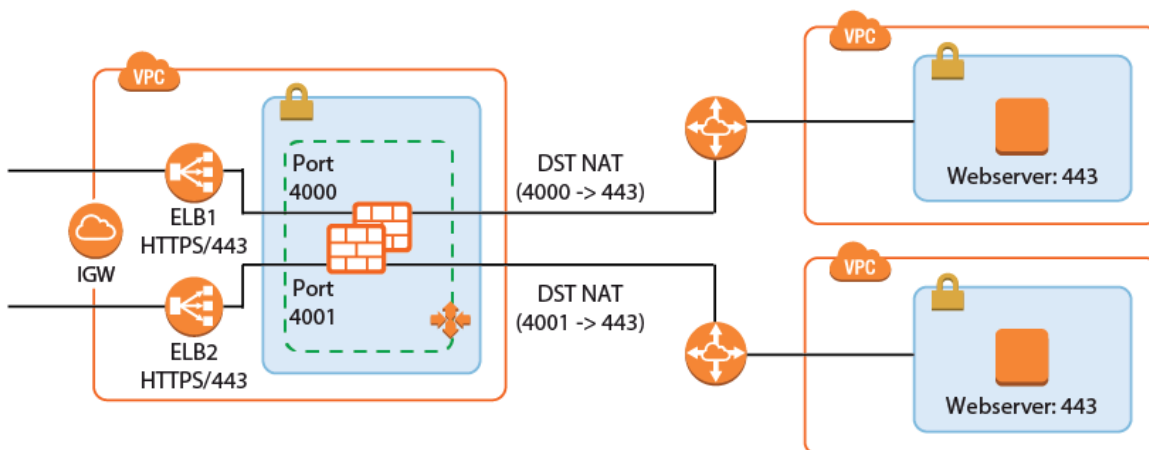

Configuration and Monitoring

Barracuda Firewall Admin is a stand-alone, multi-administrator Microsoft Windows application used to administer CloudGen Firewalls. Managing the configuration of the firewall cluster is very similar to managing a single firewall. Connect to the cluster through the ELB with a listener on TCP 807. This instance now transparently redirects the connections to other instances in the cluster as needed. Information on some tabs, such as the **CONFIGURATION** and **VPN** tabs, are aggregated by combining the data from all firewalls in the cluster. The **FIREWALL > History** page also displays connection data from all firewalls in the cluster. All other tabs and configuration elements display only the information of the firewall instance Firewall Admin is currently connected to.

- **Aggregated tabs** - All pages in the **CONFIGURATION** tab.
- **Aggregated pages** - **VPN > Client-to-Site**, **VPN > Site-to-Site** and **FIREWALL > History**.
- **Aggregated dashboard elements** - **Updates** element on the **General** dashboard.

On pages that display aggregated data from all firewall instances in the cluster, use the **Instance ID** column to filter or group the information by instance.

Login and Default Password

Connect to the firewall cluster via Firewall Admin using the FQDN of the ELB with a listener on TCP 807. The default password is the instance ID of the first instance in the Auto Scaling group. Go to the **Instance** tab of the Auto Scaling group and locate the instance that is protected from scale in to identify the first instance.

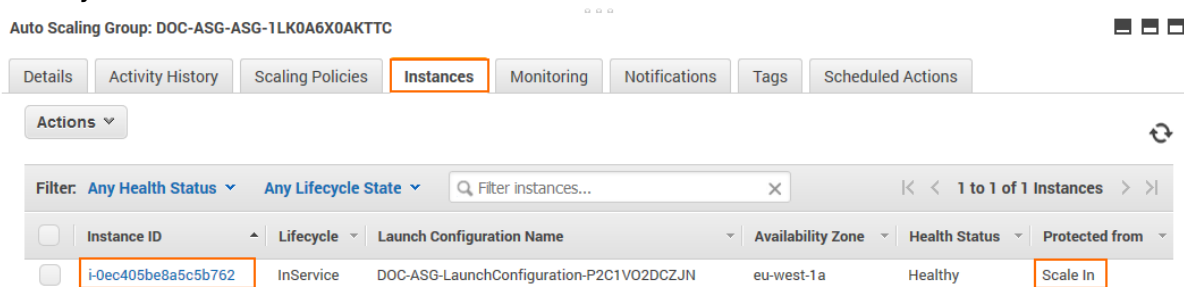

- **IP Address /Name** - Enter the DNS name of the management ELB in front of the firewall cluster.
- **User** - Enter root.
- **Password** - The default password is the instance ID of the first instance.

Barracuda CloudGen Firewall

Firewall
 Control Center
 SSH

IP Address / Name:

Username:

Password:

After logging in the first time, you are prompted to change your password.

Log Streaming to AWS CloudWatch

Log files stored on the firewall instances themselves are ephemeral. As soon as an instance is terminated, the log files are deleted with it. To keep the log files for later analysis, troubleshooting, or regulatory reasons, use syslog streaming on the firewalls to send them to AWS CloudWatch. There, the logs can be placed in groups, filtered, or processed further.

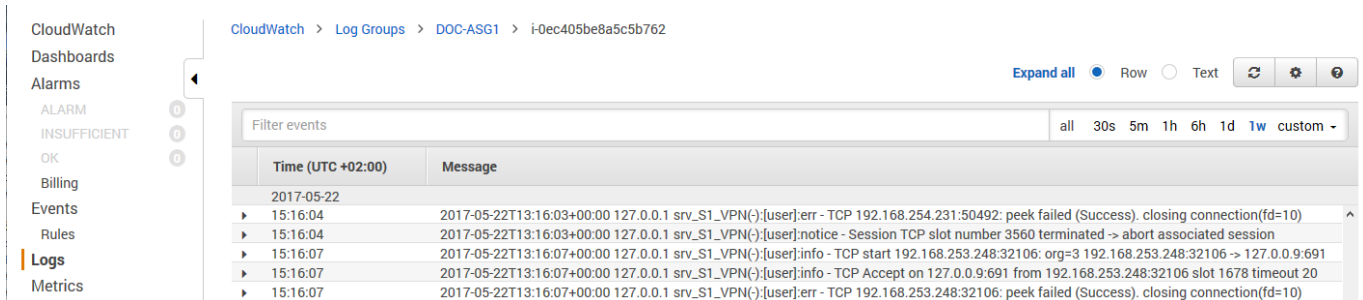

CloudWatch > Log Groups > DOC-ASG1 > i-0ec405be8a5c5b762

Expand all Row Text

Filter events all 30s 5m 1h 6h 1d 1w custom -

Time (UTC +02:00)	Message
2017-05-22	
▶ 15:16:04	2017-05-22T13:16:03+00:00 127.0.0.1 srv_S1_VPN(-)[user]:err - TCP 192.168.254.231:50492: peek failed (Success). closing connection(fd=10)
▶ 15:16:04	2017-05-22T13:16:03+00:00 127.0.0.1 srv_S1_VPN(-)[user]:notice - Session TCP slot number 3560 terminated -> abort associated session
▶ 15:16:07	2017-05-22T13:16:07+00:00 127.0.0.1 srv_S1_VPN(-)[user]:info - TCP start 192.168.253.248:32106: org=3 192.168.253.248:32106 -> 127.0.0.9:691
▶ 15:16:07	2017-05-22T13:16:07+00:00 127.0.0.1 srv_S1_VPN(-)[user]:info - TCP Accept on 127.0.0.9:691 from 192.168.253.248:32106 slot 1678 timeout 20
▶ 15:16:07	2017-05-22T13:16:07+00:00 127.0.0.1 srv_S1_VPN(-)[user]:err - TCP 192.168.253.248:32106: peek failed (Success). closing connection(fd=10)

For step-by-step instructions, see [How to Configure Log Streaming to AWS CloudWatch](#).

Monitoring and Statistics through AWS CloudWatch

Each firewall in the cluster sends both basic and custom firewall metrics to AWS CloudWatch. Using AWS CloudWatch, you can monitor and visualize these metrics through CloudWatch alarms and dashboard widgets. Monitoring alarms through the dashboard widgets allows the admin to see why auto scaling policies were applied and offers the data necessary to make improvements. The granularity at which the metrics are published can be changed. By default, metrics are published every 5 minutes. Enable detailed monitoring to lower the granularity to 1 minute. This can be configured in the template by adding this parameter to the AutoScalingGroup (ASG) resource in the template.

```
"ASG": {
  "Type": "AWS::AutoScaling::AutoScalingGroup",
  "Properties": {
    [....]
    "MetricsCollection": [{
      "Granularity" : "1Minute"
    }],
    [....]
  }
}
```

Custom VPN Metrics

- Client-to-site VPN tunnels
- SSL VPN clients
- Site-to-site VPN tunnels up
- Site-to-site VPN tunnels down

Custom System Metrics

- Load
- Used memory
- Protected IPs

Custom Firewall Metrics

- Bytes in
- Bytes out
- Bytes total
- Packets in
- Packets out
- Packets total
- Connections dropped
- IPS Hits
- Forwarding Connections new
- Forwarding Connections total
- Connections new
- Connections total
- Connections blocked
- Connections failed

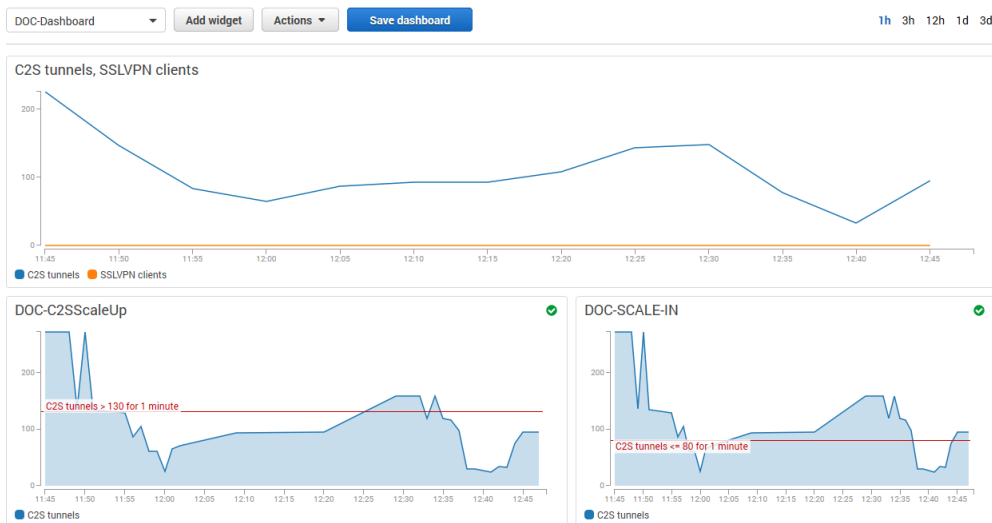

Monitoring via Firewall Admin

For remote access and firewalling workloads, the firewall cluster Firewall Admin provides more detailed, up-to-date information than is accessible through CloudWatch.

When logged in via Firewall Admin, client-to-site and SSL VPN tunnels are listed on the **VPN > Client-to-Site** and **VPN > Status** pages. The data in the **VPN** tab is aggregated from all firewall instances in the ASG. The pages list all available client-to-site and SSL VPN tunnels. On the **VPN > Status** page, the status is indicated by a colored icon in the **Tunnel** column:

- **Blue** – The client is currently connected.

- **Green** - The VPN tunnel is available, but currently not in use.
- **Grey** - The VPN tunnel is currently disabled. To enable the tunnel, right-click it and select **Enable Tunnel**.

To troubleshoot individual connections, click the client-to-site tunnel in the list and then see the error messages in the **inf** columns of the **Drop Cache** and **Access Cache** tabs.

Tunnel	Name	Type	Group	Info	State	Succ.	Fail	Last Access	Last Peer	Last Info	Last Duration
PGRP	AUTHtestuser-6pBL2		C2SP...	SM:Auth-testuser	ACTIVE	1	0	1h 43m 52s	192.168.254.41	Access Granted@172.16.213.6	1h 43m 52s
PGRP	AUTHtestuser-3WE9N		C2SP...	SM:Auth-testuser	ACTIVE	1	0	1h 43m 59s	192.168.254.41	Access Granted@172.16.106.255	1h 43m 59s
PGRP	AUTHtestuser-smHRMD		C2SP...	SM:Auth-testuser	ACTIVE	1	0	1h 44m 0s	192.168.254.41	Access Granted@172.16.190.238	1h 44m 0s
PGRP	AUTHtestuser-THEYcx		C2SP...	SM:Auth-testuser	ACTIVE	1	0	1h 44m 5s	192.168.254.41	Access Granted@172.16.92.124	1h 44m 5s
PGRP	AUTHtestuser-btKjvZ		C2SP...	SM:Auth-testuser	ACTIVE	1	0	1h 44m 8s	192.168.254.41	Access Granted@172.16.50.111	1h 44m 8s
PGRP	AUTHtestuser-lrTGSC		C2SP...	SM:Auth-testuser	ACTIVE	1	0	1h 44m 16s	192.168.253.171	Access Granted@172.16.191.237	1h 44m 16s
PGRP	AUTHtestuser-J80vSf		C2SP...	SM:Auth-testuser	ACTIVE	1	0	1h 44m 19s	192.168.253.171	Access Granted@172.16.7.3	1h 44m 19s

Access Cache:										Drop Cache:									
A.	Tun...	Name	Peer	Info	Last	S..	F..	Last Status	AID	Tun...	Name	Peer	Local	C..	L...	Info	Par		
49	PGRP	AUTHtestuser-THEYcx	192.168.254.41	SM:Auth-testuser	104 m	1	0	Granted	62	PGRP	AUTH...	192.168.254.41	127.0.0.9	13	6 s	Reverse Routing Check Fa...	172		

For more information about the **VPN > Client-to-Site** page, see [VPN Tab](#).

For more information about the **FIREWALL > History** page, see [History Page](#).

Scaling Policies - Scheduled Actions

The cluster scales to a predefined number of instances according to the time of day or date. Unhealthy or terminated instances are automatically replaced. Use scheduled scaling for predictable workloads, or to reduce the number of instances overnight when the load is low. Since one instance in the cluster is always protected from scale-in, it is not possible to completely shut down the firewall cluster. To retain high availability, at least two instances are needed. Scheduled actions are configurable in the **Scheduled Actions** tab of the Auto Scaling group settings.

Example scheduled action that scales up the cluster during the day Monday through Friday and scales back during the night and on weekends:

Create Scheduled Action

Name:

Auto Scaling Group:

Provide at least one of Min, Max and Desired Capacity

Min:

Max:

Desired Capacity:

Recurrence: Example: 0 23 * * MON-FRI

Start Time: Specify the start time in UTC
The first time this scheduled action will run

End Time: [Set End Time](#)

Create Scheduled Action

Name:

Auto Scaling Group: DOC-ASG02-ASG-1TTRR5M5WGQDW

Provide at least one of Min, Max and Desired Capacity

Min:

Max:

Desired Capacity:

Recurrence: Cron Example: 0 23 * * MON-FRI

Start Time: UTC Specify the start time in UTC
The first time this scheduled action will run

End Time: [Set End Time](#)

Scaling Policies - Dynamic Scaling

To optimize the firewall cluster to your workload, you need to select the metrics, and know how to interpret the values and the resulting action. Scaling metrics should be selected based on the use case. For example, a firewall cluster with a lot of client-to-site VPN connections should scale on the C2S Tunnels metric. If firewalling is the biggest part of the workload, it can also scale on the throughput or number of sessions, or number of dropped sessions. To achieve high availability, the firewall cluster must always use a minimum of two instances in two different Availability Zones.

Select the Relevant Metrics

To scale your firewall cluster dynamically, you must first select the metrics upon which you are going to the scale. The individual data points of the metrics can be averaged (relative performance metrics) or summed up (absolute performance metric) over a time period when creating the CloudWatch alarms. If you are adding up the data points (SUM), make sure to set the time period to match the metric collection granularity: One minute for detailed monitoring, five minutes for normal monitoring. For each metric, define upper and lower limits at which the cluster is scaled out and in. Make sure to leave enough room between the scale-out and scale-in thresholds to avoid the cluster from scaling in and out too frequently, resulting in additional cost and lower performance of the cluster. To avoid additional scaling actions before the previous action has taken effect, configure the ASG to use a cool-down period of at least 10 minutes (600 seconds). Use the CloudWatch widgets to visualize your alarms. This helps you to adjust the values to fit your workload.

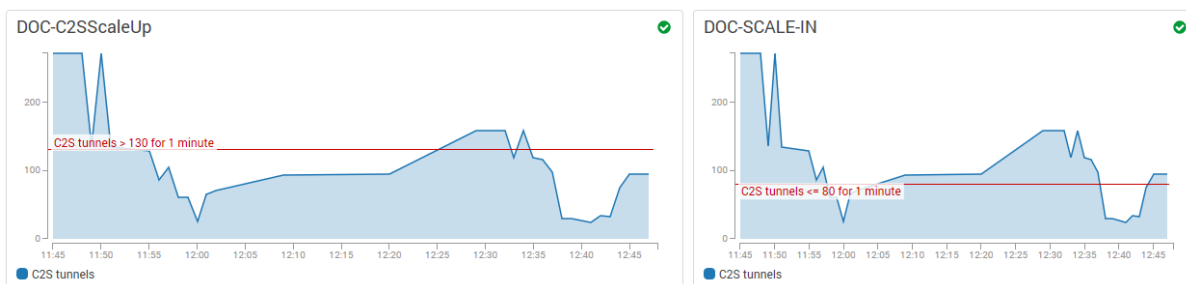

It may also help to think about how the data points collected from the firewall cluster are used in the

CloudWatch alarm:

- **Averaged metrics (default)** – Use average values over a time period that uses multiple metrics. Use longer time periods for the threshold to be more inert; shorten the time period to be more responsive. Setting the time period to a value that is too short causes the cluster to scale out and in too often, causing unnecessary cost. If in doubt use relative metrics.
- **Absolute metrics** – Set the CloudWatch alarm to add the metrics collected from the firewall cluster in the same time period that the metrics are published in. For detailed monitoring, select 1 minute, for standard monitoring 5 minutes. Using absolute values are a good choice if you want to define exact correlations between the value of a metric and the number of instances. For example: 500 client-to-site tunnels always equals 2 firewall instances; 1000 client-to-site tunnels always equals 5 instances, and so on. Absolute metrics are a good choice when the number of instances needed is non-linear.

Simple or Step Scaling

The next thing to define is if the scaling policy should always scale the same amount every time the alarm is triggered, or if there are different steps depending on by how much the value differs from the threshold value set in the alarm. Using a simple one-step scaling policy does not cope well with quickly increasing demand. By the time the scaling action has finished, the demand may have outpaced the number of available instances, forcing to scale multiple times to achieve the desired performance. This effect can be mitigated by scaling up multiple instances each time the alarm is triggered, potentially overshooting the required number of instances and incurring costs for the extra instance until the scale-in policy removes it.

For a more efficient scaling policy that covers both the slowly rising demand and quick changes, create a policy containing multiple steps. This allows you to immediately scale to the correct number of instances, thereby improving the efficiency of the cluster. Depending on the size of the step, increase the cool-down period after scaling to avoid scale-in policies from removing instances too quickly before the increased number of instances take effect.

Add Instances or Go to Exact Capacity when Scaling

The last decision before you can put your scaling policy into action is whether to simply add capacity when the alarm is triggered, or to use exact capacity numbers to match. For alarms using averaged metrics, add capacity; for absolute (SUM) metrics, set the exact capacity. Exact capacity is mainly used for non-linear workloads, whereas adding capacity is more flexible and requires less testing because the scaling threshold values are the same no matter how many instances there are in the cluster.

For step-by-step instructions, see [How to Configure Scaling Policies for a CloudGen Firewall Auto Scaling Cluster](#).

Force Reconnect on Scaling Action for Client to Site VPN

A custom parameter in the firewall can force a redistribution of all client-to-site connections on each scaling event of the cluster. All clients automatically reconnect, thereby evening out the load. Depending on the type of traffic going through the client-to-Site VPN, this action may not be transparent to the remote users because active sessions may time out and, therefore, require the user to reconnect to the backend service.

For step-by-step instructions, see [How to Configure a Client-to-Site VPN Group Policy for a CloudGen Firewall Auto Scaling Cluster in AWS](#).

Installing Hotfixes

Hotfixes are published by Barracuda Networks when an issue requires immediate attention, such as newly discovered security vulnerabilities or critical bugs in the firmware. Hotfixes are installed through the **Firewall** dashboard in Firewall Admin. New instances in the cluster automatically install the same hotfixes when the cluster scales. Most hotfixes reboot the firewall. Consider this when setting the cool-down value for scaling actions because it will take longer for an instance to be ready when multiple hotfixes need to be installed.

For step-by-step instructions, see [How to Install Updates via Barracuda Firewall Admin](#).

Firmware Update via CloudFormation Stack Update

Although possible, it is not recommended to install firmware updates like hotfixes through the **Update** element on the Firewall Admin dashboard. Instead, replace the AMI in the parameter file of your template and update the CloudFormation stack. The AMI for the new firmware version is listed in the **Manual Launch** tab of the [listing for the Barracuda CloudGen Firewall PAYG image](#) in the AWS Marketplace.

1-Click Launch
Review, modify and launch

Manual Launch
With EC2 Console, API or CLI

Service Catalog
Copy to SC and Launch

Click "Accept Software Terms" to gain access to this Software

Once you accept these terms, you will have access to this software in any supported region. You can then launch the AMIs listed below directly from the EC2 console, EC2 APIs, or with other AWS management tools.

▶ **Software Pricing**
Hourly

▶ **Version**
7.0.2-094-20170309¹, released 03/27/2017

▼ **Launch**

AMI IDs		
Region	ID	
Asia Pacific (Mumbai)	ami-661c6f09	Launch with EC2 Console
EU (London)	ami-e6716582	Launch with EC2 Console
EU (Ireland)	ami-f4cff292	Launch with EC2 Console

If your templates are stored in an S3 bucket, enter this AWS CLI command to update CloudFormation stack:

```
aws cloudformation update-stack --stack-name "YOUR_STACK_NAME" --template-body YOUR_S3_BUCKET/autoscale.json --parameter YOUR_S3_BUCKET/autoscale_parameters.json
```

```
PS C:\Users\mzoller\Documents\AWS_NGF_Official_Templates>
PS C:\Users\mzoller\Documents\AWS_NGF_Official_Templates> aws cloudformation update-stack --stack-name "DOC-ASG02" --template-body https://s3-eu-west-1.amazonaws.com/campus.deploytemplates/autoscale.json --parameter https://s3-eu-west-1.amazonaws.com/campus.deploytemplates/autoscale_parameters.json
{
  "StackId": "arn:aws:cloudformation:eu-west-1:726256585710:stack/DOC-ASG02/7bb93280-3fb3-11e7-b21d-500c3cb898d2"
}
PS C:\Users\mzoller\Documents\AWS_NGF_Official_Templates>
```

After updating the stack, scale down to one instance and manually terminate the instance protected from scale-in through the AWS CLI or EC2 web portal. All new instances that are launched now use the new AMI in the updated launch configuration. If the instance that is protected from scale-in is not terminated manually, the firewall cluster will be in an inconsistent state.

Backup / Restore

Creating a backup and restoring the firewall configuration is analog to a stand-alone CloudGen Firewall. To avoid overwriting the PAYG instance, the license must be saved prior to restoring the configuration.

To automate deployment, it also possible to modify the template to use an existing S3 bucket with a previous firewall configuration. Change the template so it does not create a new S3 bucket, and replace all references to use the existing bucket. Each firewall cluster requires a dedicated S3 bucket; it is not possible to share the configuration over multiple clusters.

For step-by-step instructions, see [How to Restore a Configuration on a PAYG Firewall in the Public Cloud](#).

Building Access Rules

By default, the firewall blocks all traffic. Only traffic matching an access rule with an allowed policy is allowed to pass. For the traffic flow to always use the same firewall, all access rules must translate the source IP address to the IP address of the DHCP interface of the firewall. It is recommended to create a custom service and network object matching your setup. This allows for easy reuse and access rules that are human-readable. Although Dst NAT access rule support basic load balancing, it is recommended to use AWS ELBs instead.

For step-by-step instructions, see [Access Rules](#), [Network Objects](#), and [Service Objects](#).

VPN Clients to Backend Services

Each VPN client is assigned an IP address in the VPN client network on the firewall the client is connected to. Since all firewalls use the same VPN client network, the source IP address must be rewritten to the IP address of the firewall instance.

- **Action** - Select **Pass**.
- **Source** - Select **Any**.
- **Service** - Select the services remote users are allowed to use, or select **Any** to allow all.
- **Destination** - Select a network object containing the backend services or networks remote users are allowed to access.
- **Connection Method** - **Dynamic NAT** or **Translated IP from DHCP Interface**.

Pass

VPNCLIENTS-2-BackendServices

Bi-Directional Dynamic Rule Deactivate Rule

Source VR Instance: default Destination VR Instance: Same as Source

Source	Service	Destination
Any 0.0.0.0/0	Any Ref: Any-TCP Ref: Any-UDP Ref: ICMP ALLIP	Backend Services 10.100.1.0/24 10.100.3.0/24 10.33.4.5

Authenticated User	Policies	Connection Method
Any	IPS Policy: Default Policy Application Policy: No AppControl SSL Inspection Policy: N.A. Schedule: Always QoS Band (Fwd): VoIP (ID 2): QoS Band (Reply): Like-Fwd:	Translated IP from DHCP Interface Network Interface: dhcp

OK Cancel

In the **TCP Policy** section of the **Advanced** access rule settings:

- **Syn Flood Protection (Fwd)** - Select **Outbound**.

TCP Policy	
Generic TCP Proxy	OFF
Syn Flood Protection (Forward)	Outbound
Syn Flood Protection (Reverse)	

In the **Dynamic Interface Handling** section of the **Advanced** access rule settings:

- **Source Interface** - Select **VPN Clients**.
- **Continue on Source Interface Mismatch** - Select **Yes**.

Dynamic Interface Handling	
Source Interface	VPNclients
Continue on Source Interface Mismatch	Yes
Reverse Interface (Bi-directional)	Matching

Internet to Backend Services

Create the following access rule to forward traffic from the Internet to an internal web server.

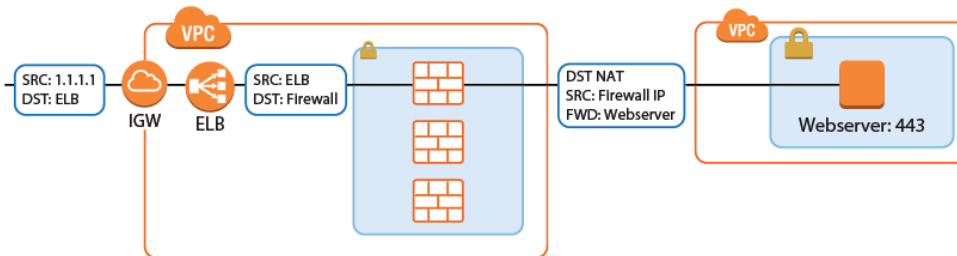

- **Action** - Select **Dst NAT**.
- **Source** - Select **Any** or a network object containing the networks the ELB is deployed in.
- **Service** - Select the service. E.g., **HTTP+S**.
- **Destination** - Select **DHCP1 Local IP**.
- **Connection Method** - Select **Dynamic NAT** or **Translated from DHCP Interface**.
- **Redirection Target** - Enter the IP address of the backend service. Optionally, append the port number to redirect to a different port. E.g, 10.100.1.2 or 10.100.1.2:8080

INET-to-WebSRVs

Dst NAT

Bi-Directional Dynamic Rule Deactivate Rule

Source VR Instance: default Destination VR Instance: Same as Source

Source	Service	Destination
Any 0.0.0.0/0	HTTPS TCP 443 https Report if not (SSL)	DHCP 1 Local IP

Redirection

Target List Reference

10.100.1.2:8080

Fallback:

List of Critical Ports:

Authenticated User	Policies	Connection Method
Any	IPS Policy: Default Policy Application Policy: No AppControl SSL Inspection Policy: N.A. Schedule: Always QoS Band (Fwd): No-Shaping QoS Band (Reply): Like-Fwd	Translated IP from DHCP Interface Network Interface: dhcp

OK Cancel

Redirect Traffic through a WAF Cluster or Other Service Behind an Internal ELB

Services behind an internal ELB can also be forwarded via Dst NAT access rule.

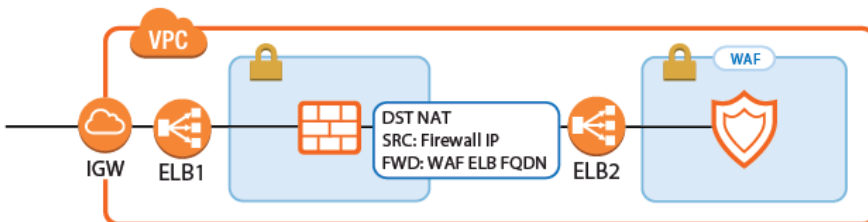

1. Create a hostname network object for the internal DNS name of the ELB, set the **DNS Lifetime** to 30 seconds, and click **Send Changes**.

Edit/Create Network Object

General

Type: Hostname (DNS Resolved)

Name:

DNS Lifetime (Sec):

2. Create the access rule:

- o **Action** - Select **Dst NAT**.
- o **Source** - Select **Any** or a network object containing the networks the ELB is deployed in.
- o **Service** - Select the service. E.g., **HTTP+S**.
- o **Destination** - Select **DHCP1 Local IP**.
- o **Connection Method** - Select **Dynamic NAT** or **Translated from DHCP Interface**.
- o **Redirection Target** - Click **Reference** and select the network object for the ELB.

Dst NAT INET-to-INTERNAL-ELB

Bi-Directional Dynamic Rule Deactivate Rule

Source VR Instance: default Destination VR Instance: Same as Source

Source	Service	Destination
Any 0.0.0.0/0	HTTP+S Ref: HTTP Ref: HTTPS	DHCP1 Local IP

Redirection

Target List: Reference

Fallback:

List of Critical Ports: 80 443

Authenticated User	Policies	Connection Method
Any	IPS Policy: Default Policy Application Policy: No AppControl SSL Inspection Policy: N.A. Schedule: Always QoS Band (Fwd): No-Shaping QoS Band (Reply): Like-Fwd	Translated IP from DHCP Interface Network Interface: dhcp

Multiple Backend Services Using the Same Port

A variation of the same rule, only this time two services running on the same port must be accessed. The ELBs in front of the firewall cluster map the service to different ports on the firewall. The firewall forwards the traffic to the correct instance or internal ELB and maps it back to the correct port.

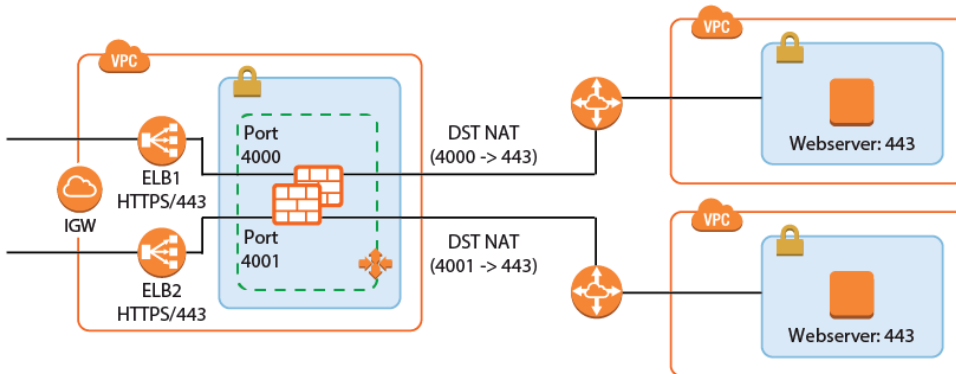

1. Add one ELB per service to the firewall cluster. Map the external port to a unique internal port. E.g., ELB1: 443 -> 4000 and ELB2 443 -> 4001
2. Create service objects for the internal ports on the firewall. Optionally, add Port Protocol Detection.

Edit/Create Service Object

Name		webApp1-HTTPS		Service Color	
Description					
Nr.	Ports / Ref			Plugin	
01	TCP 4000				

Name		webApp2-HTTPS		Service Color	
Description					
Nr.	Ports / Ref			Plugin	
01	TCP 4001				

3. Create the Dst NAT access rule for the first backend service:
 - o **Action** - Select **Dst NAT**.
 - o **Source** - Select **Any** or a network object containing the networks the ELB is deployed in.
 - o **Service** - Select the service object for the first service. E.g, webApp1-HTTPS
 - o **Destination** - Select **DHCP1 Local IP**.
 - o **Connection Method** - Select **Dynamic NAT** or **Translated from DHCP Interface**.
 - o **Redirection Target** - Enter the IP address and port of the first backend service. E.g., 10.100.1.2:443

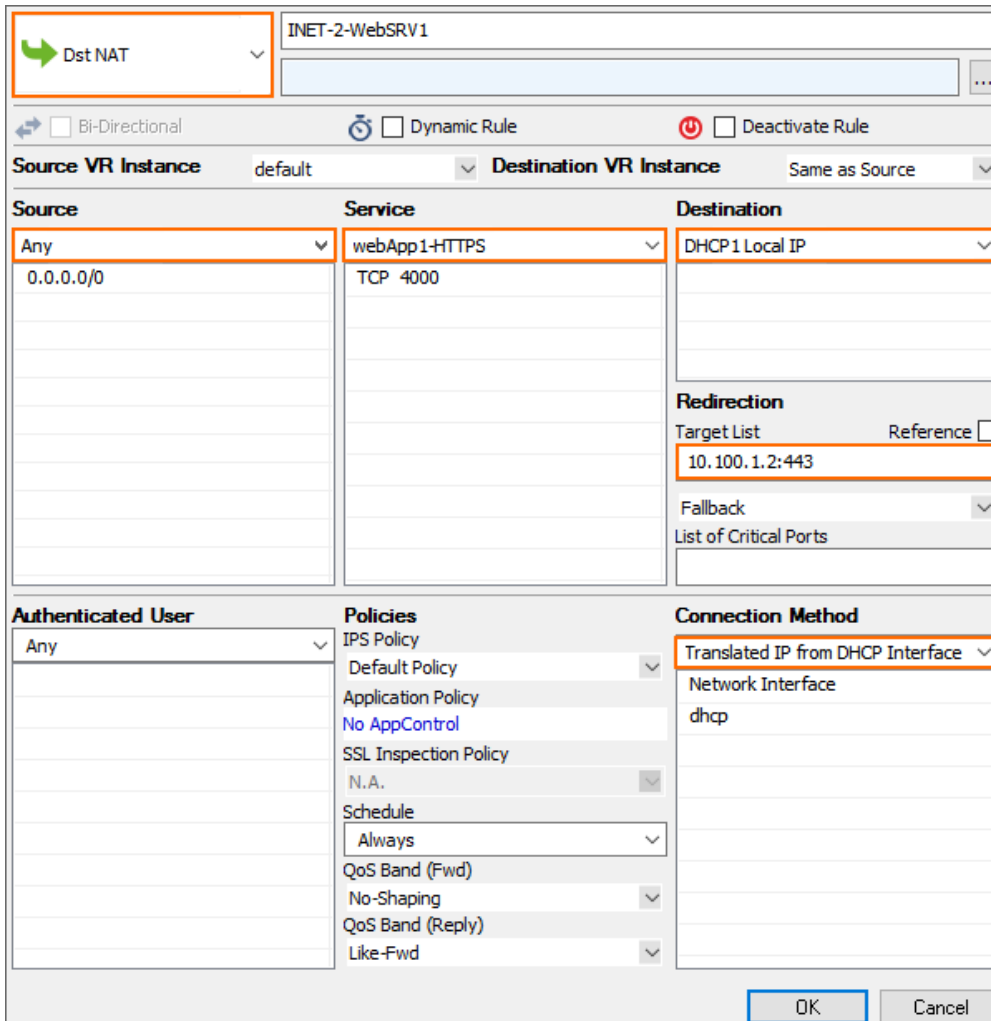

INET-2-WebSRV1

Dst NAT

Bi-Directional Dynamic Rule Deactivate Rule

Source VR Instance: default Destination VR Instance: Same as Source

Source	Service	Destination
Any 0.0.0.0/0	webApp1-HTTPS TCP 4000	DHCP1 Local IP

Redirection

Target List Reference

10.100.1.2:443

Fallback:

List of Critical Ports:

Authenticated User	Policies	Connection Method
Any	IPS Policy Default Policy Application Policy No AppControl SSL Inspection Policy N.A. Schedule Always QoS Band (Fwd) No-Shaping QoS Band (Reply) Like-Fwd	Translated IP from DHCP Interface Network Interface dhcp

OK Cancel

4. Create the Dst NAT access rule for the second backend service
 - **Action** – Select **Dst NAT**.
 - **Source** – Select **Any** or a network object containing the networks the ELB is deployed in.
 - **Service** – Select the service object for the first service. E.g, webApp2-HTTPS
 - **Destination** – Select **DHCP1 Local IP**.
 - **Connection Method** – Select **Dynamic NAT** or **Translated from DHCP Interface**.
 - **Redirection Target** – Enter the IP address and port for the second backend service
E.g., 10.111.2.4:443

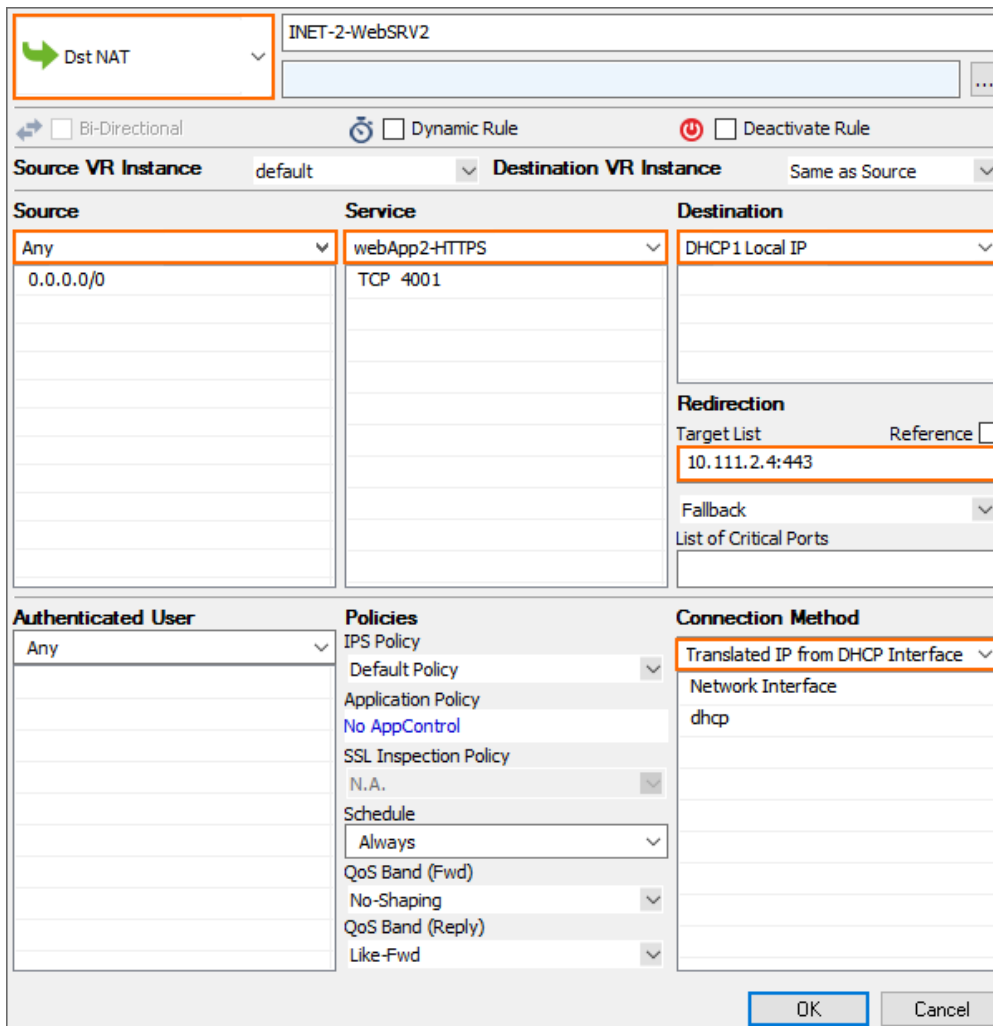

INET-2-WebSRV2

Bi-Directional Dynamic Rule Deactivate Rule

Source VR Instance: default Destination VR Instance: Same as Source

Source	Service	Destination
Any 0.0.0.0/0	webApp2-HTTPS TCP 4001	DHCP 1 Local IP

Redirection

Target List Reference

10.111.2.4:443

Fallback:

List of Critical Ports:

Authenticated User	Policies	Connection Method
Any	IPS Policy Default Policy Application Policy No AppControl SSL Inspection Policy N.A. Schedule Always QoS Band (Fwd) No-Shaping QoS Band (Reply) Like-Fwd	Translated IP from DHCP Interface Network Interface dhcp

OK Cancel

Enabling IPS per Access Rule

For the Intrusion Prevention System to scan packets matching an access rule, select the **IPS Policy** in the Pass or Dst NAT access rule. Depending on the configuration of the IPS, malicious traffic patterns are now blocked or reported. For SSL encryption, it is recommended to use SSL offloading on the ELB to allow the IPS to analyze the decrypted traffic. This saves processing power on the firewall. If end-to-end encryption is required for regulatory reasons, enable SSL Inspection on the access rule and in the IPS configuration to also scan SSL-encrypted traffic.

Policies

IPS Policy
Default Policy

Application Policy
No AppControl

Schedule
Always

QoS Band (Fwd)
VoIP (ID 2)

QoS Band (Reply)
Like-Fwd

For step-by-step instructions, see [Intrusion Prevention System \(IPS\)](#).

Figures

1. aws_autoscale_cluster_plain-01.png
2. aws_autoscale_cluster_peering-01.png
3. aws_autoscale_cluster_waf-01.png
4. aws_remote_access_autoscaling_group-01.png
5. awsIG_stack_deployed.png
6. remote_access_overview.png
7. gp_01.png
8. aws_autoscale_access_rule1.png
9. asg_default_pwd01.png
10. asg_default_pwd02.png
11. awsIG_cloudWatch01.png
12. awsIG_cloudwatch_01.png
13. awsIG_VPNtab_troubleshooting.png
14. scheduled_actions_01.png
15. scheduled_actions_02.png
16. awsIG_cloudwatch_monitor_alarms.png
17. awsIG_list_AMIs.png
18. awsIG_firmware_update_template.png
19. awsIG_access_rule_vpnclients_01.png
20. awsIG_access_rule_vpnclients_02.png
21. awsIG_access_rule_vpnclients_03.png
22. aws_autoscale_access_rule3.png
23. awsIG_dstnat_websrv01.png
24. aws_autoscale_access_rule4.png
25. awsIG_access_rule_elb_02.png
26. awsIG_access_rule_elb_01.png
27. aws_autoscale_access_rule1.png
28. awsIG_dual_service_obj1.png
29. awsIG_dual_service_obj2.png
30. awsIG_dual_access_rule01.png
31. awsIG_dual_access_rule02.png
32. awsIG_IPS.png

© Barracuda Networks Inc., 2020 The information contained within this document is confidential and proprietary to Barracuda Networks Inc. No portion of this document may be copied, distributed, publicized or used for other than internal documentary purposes without the written consent of an official representative of Barracuda Networks Inc. All specifications are subject to change without notice. Barracuda Networks Inc. assumes no responsibility for any inaccuracies in this document. Barracuda Networks Inc. reserves the right to change, modify, transfer, or otherwise revise this publication without notice.